



MIG160PFC/MIG160

MIG200PFC/MIG200

MIG250PFC/MIG250

IGBT INVERTER WELDER

Congratulations on choosing JASIC equipment! This operating manual contains important information on the use and maintenance of this product, as well as safe handling of the product. Please refer to technical parameters of the equipment in Technical Parameter in this manual, and read the manual carefully before using the equipment for the first time. For your own safety and that of your working environment, please pay particular attention to the safety instructions in the manual and operate the equipment according to the instructions. For more information on JASIC products, please contact JASIC Technology, consult an authorized JASIC dealer or visit JASIC website at www.jasictech.com.

Disclaimer

Shenzhen JASIC Technology Co., Ltd. solemnly promises that this product is manufactured according to relevant domestic and international standards, and that this product conforms to EN60974-1 International Safety Standard. The relevant design scheme and manufacturing technology adopted in this product are protected by patents.

1. While every effort has been made to ensure that the information contained in this manual is accurate and complete, no liability will be accepted for any errors or omissions due to the operation not according to this manual.
2. JASIC reserves the right to change the manual at any time without prior notice.
3. Though contents in this manual have been carefully checked, there might be inaccuracies. Please contact us in case of inaccuracy.
4. Do not copy, record, reproduce or transmit the contents of this manual without prior permission from JASIC.

Manufacturer: Shenzhen JASIC Technology Co. Ltd

Registered Trademark: JASIC

Registered Address: No.3 Qinglan 1st Road, Pingshan District, Shenzhen, Guangdong, China

Postcode: 518118

Tel: +86 (0755) 8670 6250

Fax: +86 (0755) 27364108

Website: www.jasictech.com

E-mail: sales@jasictech.com

Contents

1. Safety precautions.....	6
1.1. General safety.....	6
1.2. Other precautions.....	9
2. Description of symbols.....	10
3. Product overview.....	12
4. Technical parameters.....	14
5. Installation.....	17
5.1. External interface description.....	17
5.2. Power installation.....	19
5.3. MIG welding torch and earth cable connection.....	20
5.4. MMA electrode holder and earth cable connection.....	22
5.5. Lift TIG welding torch and earth cable connection.....	23
5.6. Wired handheld remote controller / foot pedal controller connection (optional).....	24
5.7. Installation of wireless receiver module (optional).....	24
6. Control panel.....	25
6.1. Overview.....	25
6.2. Barcode display.....	32
6.3. Restore factory settings.....	32
6.4. Welding engineer mode functions.....	34
7. Welding function operation.....	36
7.1. MIG operation.....	36
7.2. MMA operation.....	42
7.3. Lift TIG operation.....	44
7.4. Standby.....	46
7.5. Functions and use of wireless/wired remote controller.....	46
8. Maintenance.....	47
8.1. Power supply maintenance.....	47
9. Troubleshooting.....	48
9.1. Common malfunction analysis and solution.....	48
9.2. Alarm and solutions.....	52
9.3. Common MIG malfunction.....	53
10. Packaging, transportation, storage and waste disposal.....	54
10.1. Transportation requirements.....	54
10.2. Storage conditions.....	54
10.3. Waste disposal.....	54
11. After-sales service.....	55
11.1. Warranty card.....	55
11.2. Maintenance.....	55
Appendix.....	56
Appendix 1: Wiring diagram.....	56
Appendix 2: List of common spare parts.....	60
Appendix 3 Packaging and parts.....	70

For your safety, please read this manual carefully before installing and operating this JASIC equipment.

Pay extra attention to all content marked with "  ".

All operations must be carried out by professional, suitably qualified persons!

1. Safety precautions

1.1. General safety



SAFETY INSTRUCTION

These general safety norms cover both arc welding machines and plasma cutting machines unless otherwise noted.

It is important that users of this equipment protect yourselves and others from harm or even death.

The equipment must only be used for the purpose it was designed for. Using it in any other way could result in damage or injury and in breach of the safety rules.



Only suitably trained and competent persons should use the equipment.



Pacemaker wearers should consult your doctor prior to using this equipment

PPE and workplace safety equipment must be compatible for the application of work involved.

Always carry out a risk assessment before carrying out any welding or cutting activity

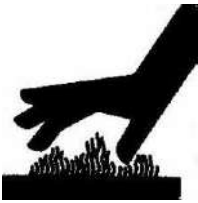
	<p>Only qualified personnel should operate this machine!</p> <ul style="list-style-type: none"> ·Always use the appropriate personal protective equipment. ·Always pay attention to the safety of other persons around the working zone ·Do not carry out any maintenance with the power on the machine
	<p>Electric shock—May cause serious injury or even death!</p> <ul style="list-style-type: none"> ·The equipment should be installed by a qualified person and in accordance with current standards in operation. It is the user's responsibility to ensure that the equipment is connected to a suitable power supply. Consult with your utility supplier if required. Do not use the equipment with the covers removed. ·Do not touch live electrical parts or parts, which are electrically charged. ·Turn off all equipment when not in use.
	<p>Fumes and gases—May be hazardous to your health.</p> <p>Locate the equipment in a well-ventilated position and keep your head out of the fume.</p> <p>Do not breathe the fume.</p> <p>Ensure the working zone is well ventilated and provision should be made for suitable local fume extraction system to be in place.</p> <p>If ventilation is poor, wear an approved air fed welding helmet or respirator.</p> <p>Read and understand the Material Safety Data Sheets (MSDS's) and the manufacturer's instructions for metals, consumable, coatings, cleaners and de-greasers.</p> <p>Do not work in locations near any de-greasing, cleaning or spraying operations. Be aware that heat and rays of the arc can react with vapours to form highly toxic and irritating gases.</p>

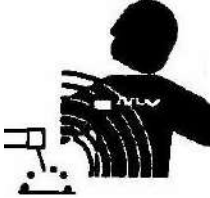
	<p>Arc rays—May injure the eyes and burn the skin.</p> <p>The arc rays from all processes produce intense, visible and invisible (ultraviolet and infrared) rays that can burn eyes and skin.</p> <ul style="list-style-type: none"> ·Wear an approved welding helmet fitted with an appropriate shade of filter lens to protect your face and eyes when working or watching. ·Wear approved safety glasses with side shields under your helmet. ·Never use broken or faulty welding helmets. ·Always ensure there are adequate protective screens or barriers to protect others from flash, glare and sparks from the working area. ·Ensure that there are adequate warnings that welding or cutting is taking place. ·Wear suitable protective flame resistant clothing, gloves and footwear.
	<p>Precautions against fire and explosion</p> <p>Avoid causing fires due to sparks and hot waste or molten metal.</p> <p>Ensure that appropriate fire safety devices are available near the welding and cutting area.</p> <p>Remove all flammable and combustible materials from the welding, cutting and surrounding areas.</p> <p>Do not weld or cut fuel and lubricant containers, even if empty. These must be carefully cleaned before they can be welded or cut.</p> <p>Always allow the welded or cut material to cool before touching it or placing it in contact with combustible or flammable material.</p> <p>Do not work in atmospheres with high concentrations of combustible fumes, flammable gases and dust.</p> <p>Always check the work area half an hour after cutting to make sure that no fires have begun.</p> <p>Take care to avoid accidental contact of electrode to metal objects. This could cause arcs, explosion, overheating or fire.</p>
	<p>Risks due to hot material</p> <p>The process will create hot metal, sparks and drips of molten metal, so it's very important to ensure the operator is equipped with full PPE and to always ensure there are adequate protective screens or barriers to protect others from flash, glare and sparks from the working area. Hot surfaces will create fires and will burn any exposed skin.</p> <p>Always protect your eyes and body. Use the correct welding screen and filter lens and wear full PPE protective clothing.</p> <p>Do not touch any hot surfaces or parts bare handed.</p> <p>Always allow hot surfaces and parts to cool down first before touching or moving.</p> <p>If you are required to move hot parts, ensure you use proper tools and insulated welding gloves (PPE) to prevent burns to your hands and arms.</p>

	<p>Noise—Excessive noise may be harmful to hearing</p> <ul style="list-style-type: none"> ·Protect your ears by ear shields or other hearing protectors. ·Give warning to nearby personnel that noise may be potentially hazardous to hearing.
	<p>Risks due to magnetic fields</p> <p>The magnetic fields created by high currents may affect the operation of pacemakers or electronically controlled medical equipment.</p> <p>Wearers of vital electronic equipment should consult their physician before beginning any arc welding, cutting, gouging or spot welding operations.</p> <p>Do not go near welding equipment with any sensitive electronic equipment as the magnetic fields may cause damage.</p> <p>Keep the torch cable and work return cable as close to each other as possible throughout their length, this can help minimize your exposure to harmful magnetic fields.</p> <p>Do not wrap the cables around the body.</p>
	<p>Protection from moving parts</p> <p>When the machine is in operation keep away from moving parts such as motors and fans.</p> <p>Moving parts, such as the fan, may cut fingers and hands and snag garments.</p> <p>Protections and coverings may be removed for maintenance and controls only by qualified personnel after first disconnecting the power supply cable.</p> <p>Replace the coverings and protections and close all doors when the intervention is finished and before starting the equipment.</p> <p>Take care to avoid getting fingers trapped when loading and feeding wire during set up and operation.</p> <p>When feeding wire be careful to avoid pointing it at other people or towards your body.</p> <p>Always ensure machine covers and protective devices are in operation.</p>
	<p>Troubleshooting</p> <p>Before the machines are dispatched from the factory, they have already been checked thoroughly. The machine should not be tampered with or altered.</p> <p>Maintenance must be carried out carefully. If any wire becomes loose or is misplaced, it maybe potentially dangerous to user!</p> <p>Only professional maintenance personnel should repair the machine!</p> <p>Ensure the power is disconnected before working on the machine. Always wait 5 minutes after power switch off before removing the panels.</p> <p>If you still do not fully understand or cannot solve the problem after reading the instructions in this manual, you should contact the supplier or JASIC's service center immediately for professional help.</p>

1.2. Other precautions



Warning! Location

The machine should be located in a suitable position and environment. Care should be taken to avoid moisture, dust, steam, oil or corrosive gases. Place on a secure level surface and ensure that there is adequate clearance around the machine to ensure natural airflow.



Warning! The handle or strap on the machine is only suitable for manual lifting of the machine. If mechanical equipment such as crane is used to lift the machine, please ensure the machine is secured with suitable lifting equipment.



Warning!

Input connection













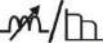

Before connecting the machine, you should ensure that the correct supply is available. Details of the machine requirements can be found on the data plate of the machine or in the technical parameters shown in the manual. The equipment should be connected by a suitably qualified competent person.

Always ensure the equipment has a proper grounding.

Never connect the machine to the mains supply with the panels removed.

- 1) When the operator's movement is limited by the surroundings (for example, the operator can only bend his knees, barefoot, or lie down during operation), the operator shall practice proper insulation and avoid direct contact with conductive parts on the equipment.
- 2) Do not use the machine in closed containers in narrow spaces where conductive components cannot be removed.
- 3) Do not use the machine in humid environments where the operator is prone to the risk of electric shock.
- 4) Do not use the machine in sunlight or rain, and no water or rainwater shall seep into the machine.
- 5) Do not perform gas shielded welding in an environment with strong air flow.
- 6) Avoid welding or cutting in dusty area or environment with corrosive chemical gas.
- 7) The ambient temperature must be between -10°C and 40°C during operation and between -25°C and 50°C during storage.
- 8) Welding or cutting shall be carried out in a relatively dry environment, and the air humidity shall not exceed 90%.
- 9) The inclination of the machine shall not exceed 10°.
- 10) Ensure that the input power supply voltage does not exceed 15% of the rated voltage of the machine.
- 11) Beware of falling when welding or cutting at heights.

2. Description of symbols

	Warning! Read the Manual
	Electric shock risk warning
	WEEE tag
A	Current unit "A"
m/min	Wire feed speed unit "m/min"
	Thickness of welding base metal "mm"
V	Voltage unit "V"
	Inductance of MIG/arc force of MMA
	MIG burn back time unit "ms"
	Overheat protection indicator
	Overcurrent protection indicator
	VRD function indicator
	MMA mode
	MIG mode
	Lift TIG mode
	Welding mode switching
Steel Ar80% CO₂20%	Mixed gas welding (80% argon + 20% CO ₂) of carbon steel
Steel FluxCored Ar80% CO₂20%	Mixed gas welding (80% argon + 20% CO ₂) of flux-cored carbon steel
Steel FCW-SS	Self-shielded welding of carbon steel
AlMg Ar100%	100% argon shielding of aluminum magnesium alloy
CrNi Ar98% CO₂2%	Mixed gas welding (98% argon + 2% CO ₂) of stainless steel
	Welding type selection: welding base metal and gas

φ 0.6

φ 0.8

φ 1.0

φ 1.2

Welding wire diameter



MIG/Lift TIG 2T operation



MIG/Lift TIG 4T operation



MIG push torch



MIG spool torch



Other function switching



Remote controller



MIG synergic function



Inching wire feeding function



Gas check function

3. Product overview

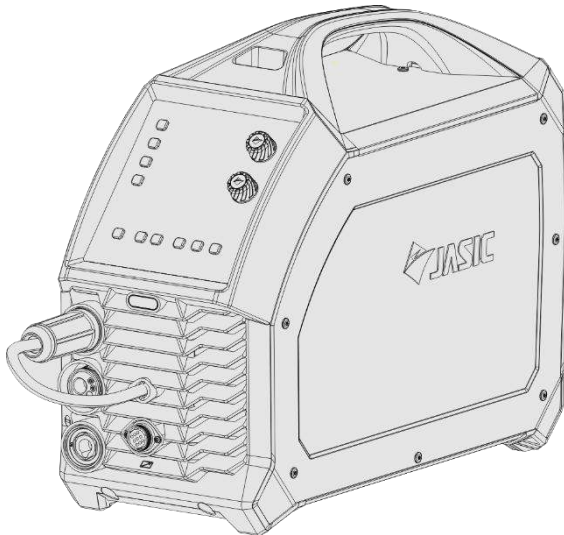

MIG160/MIG200 series

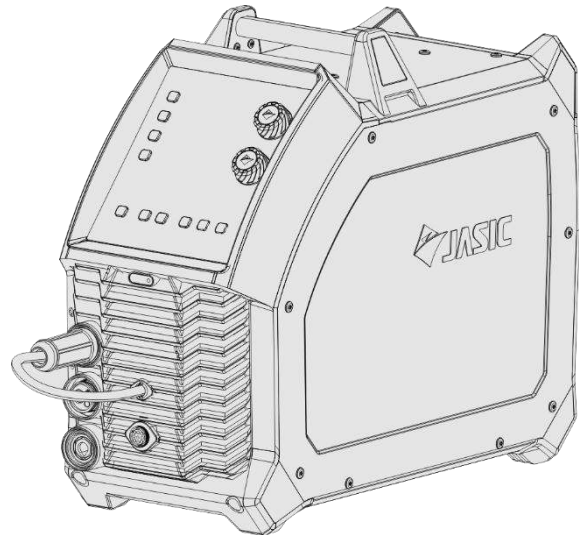

MIG250 series

This series are digital multi-process inverter DC MIG welders featuring advanced technology with excellent performance. They can be used to weld carbon steel, low-alloy steel, aluminum magnesium alloy and stainless steel, etc. The MIG mode of the welder features preset wire feed speed and welding voltage. The welders also have a built-in "Synergic" expert parameter library for welding wires of different diameters under different shielding gases and base metals. After setting the welding wire diameter, shielding gases and base metal through the panel, the operator sets one of the welding current, wire feed speed and plate thickness, and the welder automatically finds the corresponding welding voltage to achieve good welding results. With adjustable arc-force in MMA and torch-control Lift TIG modes, these welders have wider applications.

These inverter welders support **DC MIG**, **DC MMA** and **Lift TIG** welding modes and can be widely used to weld various metals. The unique electrical structure and zoning diversion-type air passage design inside the machine increases the heat dissipation efficiency, thus improving its duty cycle. Benefitting from the unique air passage design, the machine effectively prevents damage to the power device and control circuits from dust drawn in by the fan, thus greatly improving its reliability.

The main functions include:

- ◆ Three welding modes: MIG, MMA and Lift TIG.
- ◆ In MIG mode, preset the wire feed speed, welding voltage, welding inductance and burn back time.
- ◆ Supports selection of gas check, inching wire feeding and wire diameter.
- ◆ "Synergic" function: The welder automatically matches the parameters according to the welding wire diameter, gas and base metal after setting the current, wire feed speed, and plate thickness, making it easier to use.
- ◆ Can be equipped with a digital/analog push torch or analog spool torch.
- ◆ In MMA mode, preset the current and arc force, making the current adjustment more

accurate.

- ◆ Anti-stick function: Prevents the welding electrode from sticking to the work piece during welding.
- ◆ MMA hot start function: Makes MMA arc ignition easier and more reliable.
- ◆ Lift TIG is controlled by the welding torch.
- ◆ On-demand fan: Prolongs the life span of fan and reduces accumulation of dust inside the machine.
- ◆ Parameters are automatically saved before shutdown, and the settings are restored after starting again.
- ◆ Factory settings parameter restore function.
- ◆ Standby function: In MIG and Lift TIG mode, the machine automatically enters standby state if it is not used for a long time.
- ◆ Optional wired handheld remote controller and wireless remote controller.(Not optional for standard version which has no remote control interface)

4. Technical parameters

Item	Unit	MIG160/MIG200/MIG250 Parameters		
Model	/	MIG250	MIG200	MIG160
Input voltage	V _{AC}	AC230V±15%	AC230V±15%	AC230V±15%
Input frequency	Hz	50/60	50/60	50/60
Rated input current (AC230V)	A	46.3@MIG 33.5@TIG 41.3@MMA	46@MIG 32@TIG 36@MMA	46@MIG 26@TIG 29@MMA
Rated input power (AC230V)	kVA	10.51@MIG 9.08@TIG 10.15@MMA	8.85@MIG 7.53@TIG 8.81@MMA	7.28@MIG 5.98@TIG 7.26@MMA
Output current range (MIG)	V	11~30	11~28	11~26
Wire feed speed range (MIG)	m/min	2~18	2~15	2~14
Output current range (MIG)	A	30~250	30~200	30~160
Output current range (Lift TIG)	A	5~250	5~200	5~160
Output current range (MMA)	A	20~220	20~180	20~140
Arc force range	A	0~60, 30 by default	0~60, 30 by default	0~60, 30 by default
Hot start current range	A	60	60	60
No-load voltage	V	60	60	60
VRD voltage	V	10.5	10.1	10.1
Rated working voltage	V	26.5@MIG 20@TIG 28.8@MMA	24@MIG 18@TIG 27.2@MMA	22@MIG 16.4@TIG 25.6@MMA
Efficiency (%)	/	85.74%@MIG 83.67%@TIG 87.44%@MMA	81.39%@MIG 80.51%%@TIG 85.49%@MMA	83.6%@MIG 81.2% @TIG 85.7%@MMA
Duty cycle (%)	/	30%@MIG 30%@TIG 30%@MMA	30%@MIG 30%@TIG 30%@MMA	30%@MIG 30%@TIG 30%@MMA

Power factor	/	0.73@MIG 0.66@TIG 0.72@MMA	0.65@MIG 0.59@TIG 0.65@MMA	0.58@MIG 0.54@TIG 0.58@MMA
Insulation class	/	H	H	H
Protection class	/	IP23S	IP23S	IP23S
Dimensions L*W*H	mm	700*280*511	565*220*415	565*220*415
Net weight	Kg	24@ plus	15@ plus	15@ plus
		23.7@ standard	14.7@ standard	14.5@ standard
Overall total weight	Kg	31.3@ plus	20.7@ plus	20.7@ plus
		30@ standard	19.9@ standard	19.7@ standard
Idle state power	W	<50	<50	<50
Characteristics	/	CC/CV	CC/CV	CC/CV
Pollution level	/	Grade 3	Grade 3	Grade 3

Item	Unit	MIG160PFC/MIG200PFC/MIG250PFC Parameters		
Model	/	MIG250PFC	MIG200PFC	MIG160PFC
Input voltage	VAC	AC230V±15%	AC230V±15%	AC230V±15%
Input frequency	Hz	50/60	50/60	50/60
Rated input current (AC230V)	A	43.7@MIG	38.3@MIG	33@MIG
		26.6@TIG	19.1@TIG	14.4@TIG
		31.9@MMA	25@MMA	18.5@MMA
Rated input current (AC115V)	A	38.7@MIG	41.8@MIG	37.5@MIG
		28.9@TIG	23.7@TIG	16.4@TIG
		33@MMA	28.5@MMA	25.3@MMA
Rated input power (AC230V)	kVA	7.84@MIG	5.74@MIG	4.22@MIG
		6.07@TIG	4.43@TIG	3.23@TIG
		7.34@MMA	5.77@MMA	4.19@MMA
Rated input power (AC115V)	kVA	4.32@MIG	3.68@MIG	2.98@MIG
		3.31@TIG	2.79@TIG	1.79@TIG
		3.75@MMA	3.28@MMA	2.26@MMA
Output voltage range (MIG)	V	11~30@230V	11~28@230V	11~26@230V
		11~25@115V	11~24@115V	11~22@115V
Wire feed speed range (MIG)	m/min	2~18@230V	2~15@230V	2~14@230V
		2~13@115V	2~13@115V	2~11@115V
Output current range (MIG)	A	30~250@230V	30~200@230V	30~160@230V
		30~160@115V	30~140@115V	30~120@115V

Output current range (TIG)	A	5~250@230V 5~160@115V	5~200@230V 5~140@115V	5~160@230V 5~100@115V
Output current range (MMA)	A	20~220@230V 20~125@115V	20~180@230V 20~110@115V	20~140@230V 20~100@115V
Arc force range	A	0~100	0~100	0~100
Hot start current range	A	0~60, 30 by default	0~60, 30 by default	0~60, 30 by default
No-load voltage	V	65	67	67
VRD voltage	V	10.1	10.1	10.1
Rated working voltage	V	26.5@MIG 20@TIG 28.8@MMA	24@MIG 18@TIG 27.2@MMA	22@MIG 16.4@TIG 25.6@MMA
Efficiency (%) (230V)	/	84.88@230V MIG 83.97@230V MMA 82.8@230V TIG	83.86@230V MIG 85.46@230V MMA 81.72@230V TIG	84.03@230V MIG 85.88@230V MMA 81.69@230V TIG
Efficiency (%) (115V)	/	81.55@115V MIG 83.57@115V MMA 79.6@115V TIG	80.24@115V MIG 82.50@115V MMA 78.36@115V TIG	80.65@115V MIG 82.91@115V MMA 78.32@115V TIG
Duty cycle (%)	/	30@MIG 30@TIG 30@MMA	25@MIG 25@TIG 25@MMA	30@MIG 30@TIG 30@MMA
Power factor	/	0.99	0.99	0.99
Insulation class	/	H	H	H
Protection class	/	IP23S	IP23S	IP23S
Dimensions L*W*H	mm	700*280*511	565*220*415	565*220*415
Net weight	Kg	25.5@ plus	16@ plus	16@ plus
		25.2@ standard	15.7@ standard	15.5@ standard
Overall total weight	Kg	32.8@ plus	21.8@ plus	21.8@ plus
		31.2@ standard	21@ standard	20.8@ standard
Idle state power	W	<50	<50	<50
Characteristics	/	CC/CV	CC/CV	CC/CV
Pollution level	/	Grade 3	Grade 3	Grade 3

5. Installation



Warning! All connections shall be made with the power supply is turned off.
Warning! Electric shock may cause death; after power failure, there is still a high voltage on the equipment, do not touch the live parts on the equipment.
Warning! Incorrect input voltage may damage the equipment.
Warning! This product meets the requirements of Class A equipment in EMC requirements and is not to be connected to a residential low-voltage power supply grid.

5.1. External interface description

MIG160/MIG160PFC/MIG200/MIG200PFC series

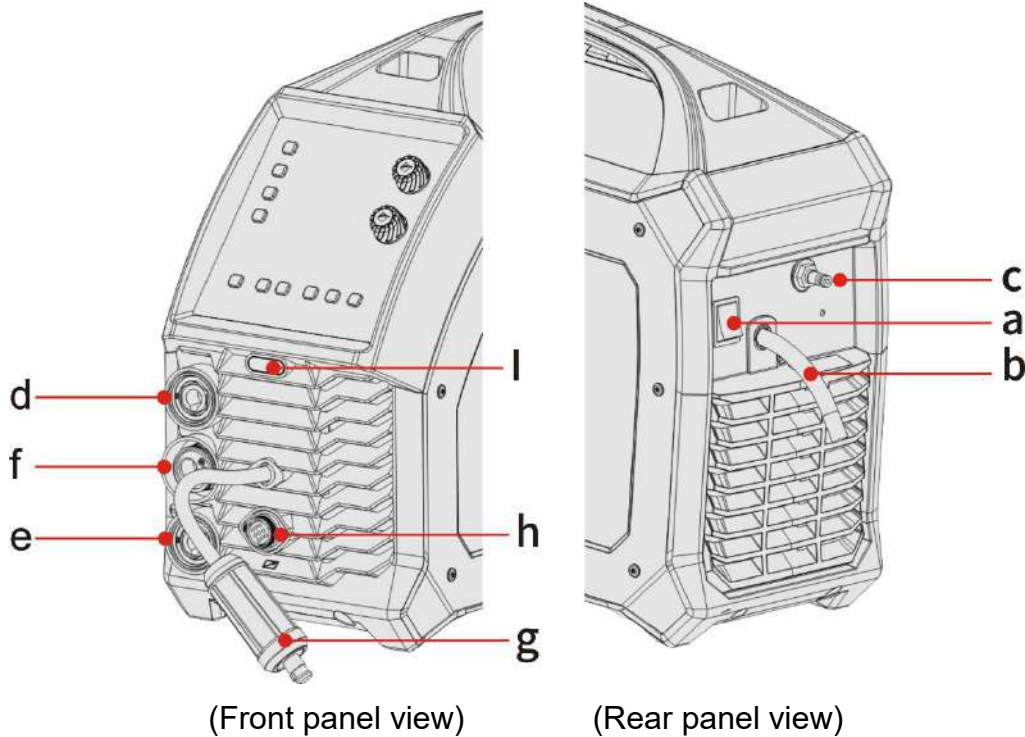

- a. Power switch
- b. Input power cord
- c. Inlet nozzle of gas valve
- d. Positive polarity
- e. Negative polarity
- f. Central socket
- g. Polarity changeover connector
- h. 9-pin aviation socket (optional)
- i. Wireless receiver module (optional)

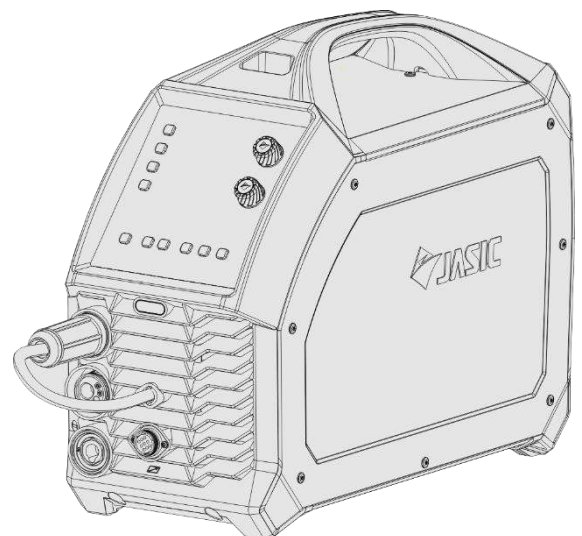

MIG250/MIG250PFC series

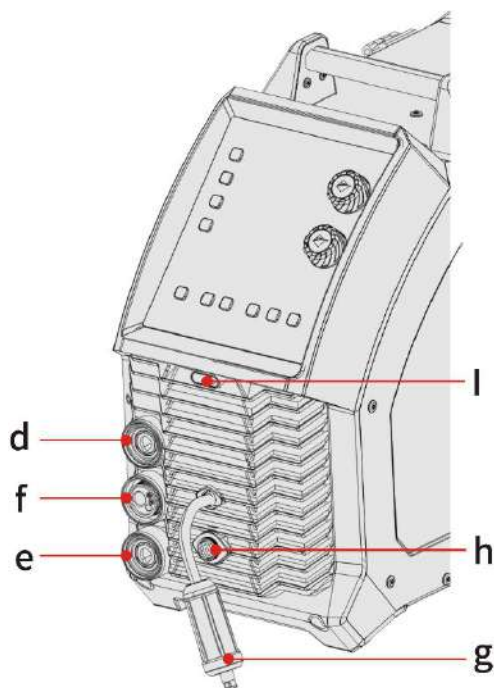

(Front panel view)

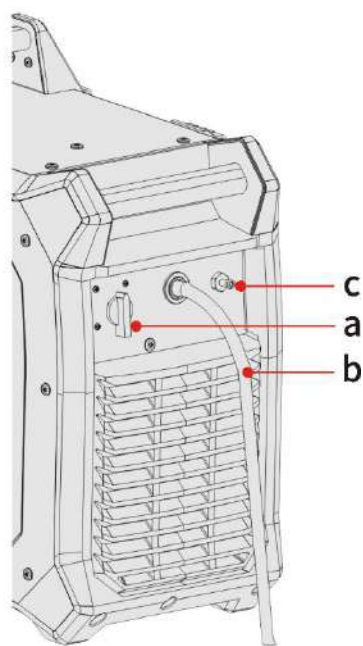

(Rear panel view)

- a. Power switch
- b. Input power cord
- c. Inlet nozzle of gas valve
- d. Positive polarity
- e. Negative polarity
- f. Central socket
- g. Polarity changeover connector
- h. 9-pin aviation socket (optional)
- i. Wireless receiver module (optional)

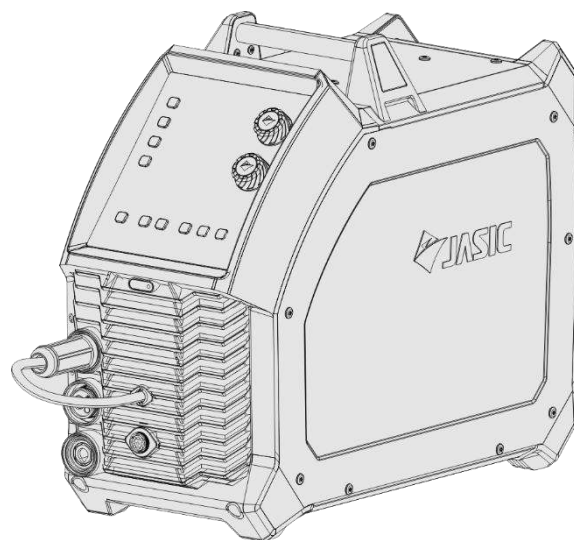

5.2. Power installation



Warning! The electrical connection of equipment shall be carried out by suitably qualified personnel.

Warning! All connections shall be made after the power supply is off.

Warning! Incorrect voltage may damage the equipment.

- 1) Ensure the input voltage value is within the specified input voltage range.
- 2) Ensure that the power switch is turned off.
- 3) Connect the input power cord to the input terminal or plug the power cord into the corresponding socket (if any) and ensure a good contact.
- 4) Ground the power supply well. (As shown in the diagram, the European plug has a grounding terminal, so no additional grounding is required.)

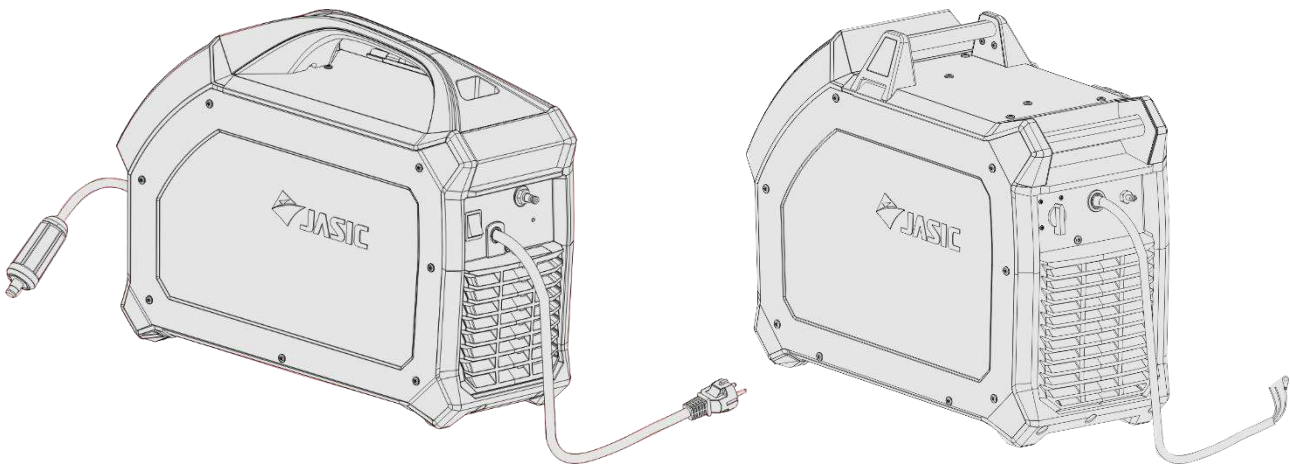

NOTE!

If the input cable needs to be extended, please use a cable with larger cross-sectional area to reduce the voltage drop, 3x2.5mm² or more is recommended.

5.3. MIG welding torch and earth cable connection

5.3.1 Digital/analog MIG welding torch

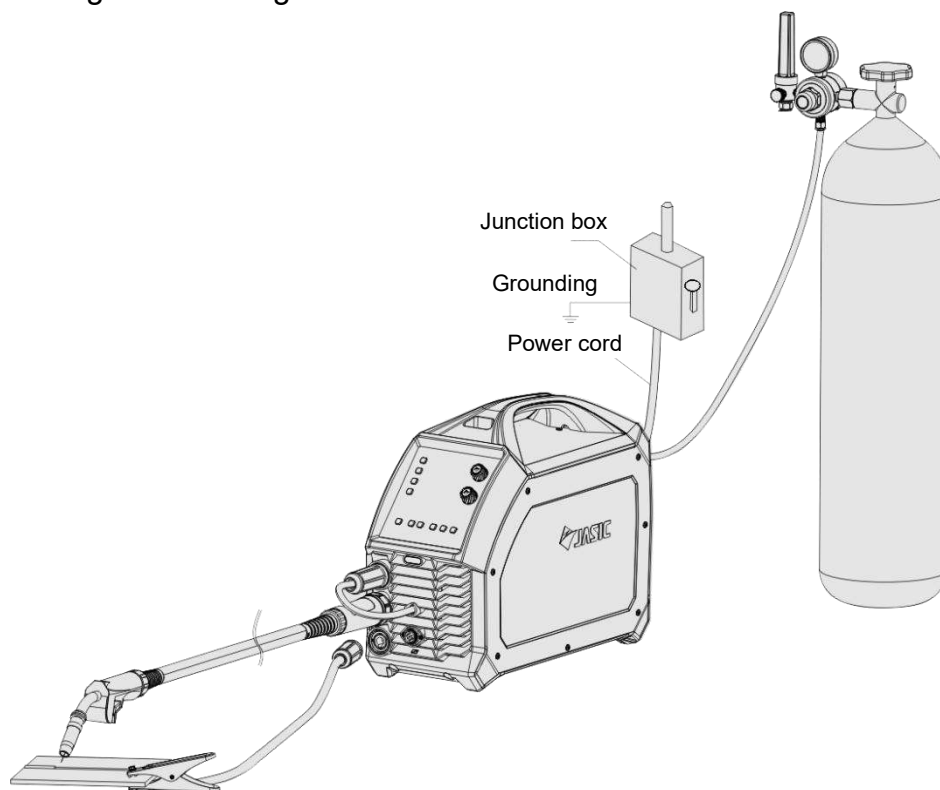

(Wiring diagram of MIG: DCEP)

Pay attention to the polarity of wiring before MIG. Generally, there are two connection methods of DC welder: DCEN and DCEP.

DCEN: The workpiece is connected to the positive polarity, and the polarity changeover connector is connected to the negative polarity;

DCEP: The workpiece is connected to the negative polarity, and the polarity changeover connector is connected to the positive polarity.

If MIG is selected, except for carbon steel flux-cored self-shielded welding, which uses DCEN, these welders generally use DCEP for other gas-shielded welding types:

- 1) Ensure that the power switch of the welder itself is turned off.
- 2) Insert the torch plug into the central socket on the front panel of the welder and tighten it clockwise.
- 3) Insert the cable plug with earth clamp into the negative polarity socket on the front panel of the welder and tighten it clockwise.
- 4) Insert the polarity changeover connector into the positive polarity socket on the front panel of the welder and tighten it clockwise.
- 5) Connect one end of the gas hose to the gas valve inlet on the rear panel of the welder, and the other end to the gas regulator outlet, and secure it with a clamp.

5.3.2 Spool torch

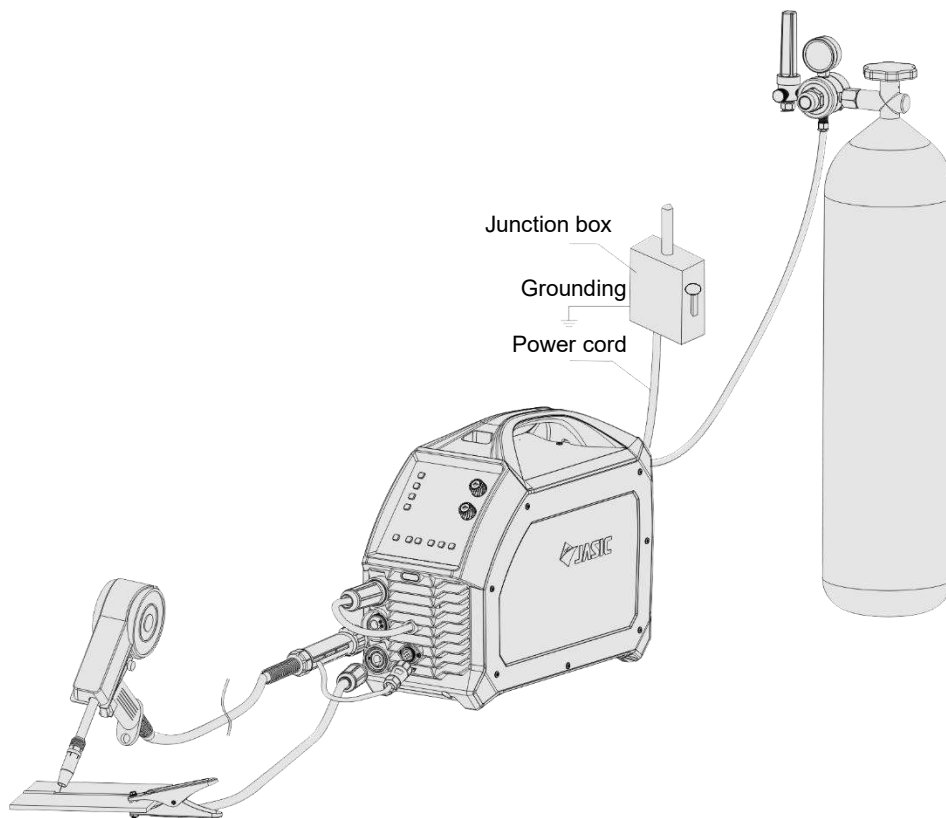

(Wiring diagram of spool torch: DCEP)

Pay attention to the polarity of wiring before MIG. See section 5.3.1 for details. Take DCEP as an example:

- 1) Ensure that the power switch of the welder itself is turned off.
- 2) Insert the torch plug into the central socket on the front panel of the welder and tighten it clockwise.
- 3) Insert the 9-pin control plug of the welding torch into the 9-pin aviation socket on the front panel of the welder and tighten it clockwise.
- 4) Insert the cable plug with earth clamp into the negative polarity socket on the front panel of the welder and tighten it clockwise.
- 5) Insert the polarity changeover connector into the positive polarity socket on the front panel of the welder and tighten it clockwise.
- 6) Connect one end of the gas hose to the gas valve inlet on the rear panel of the welder, and the other end to the gas regulator outlet, and secure it with a clamp.

Note! When performing carbon steel flux-cored self-shielded welding, please replace with dedicated knurling wire feed roller and use "DCEN".

When performing aluminum magnesium alloy welding, please replace with U-groove wire feed roller, contact tip, and 2.0mm diameter Teflon liner for aluminum welding, and use "DCEP".

5.4. MMA electrode holder and earth cable connection

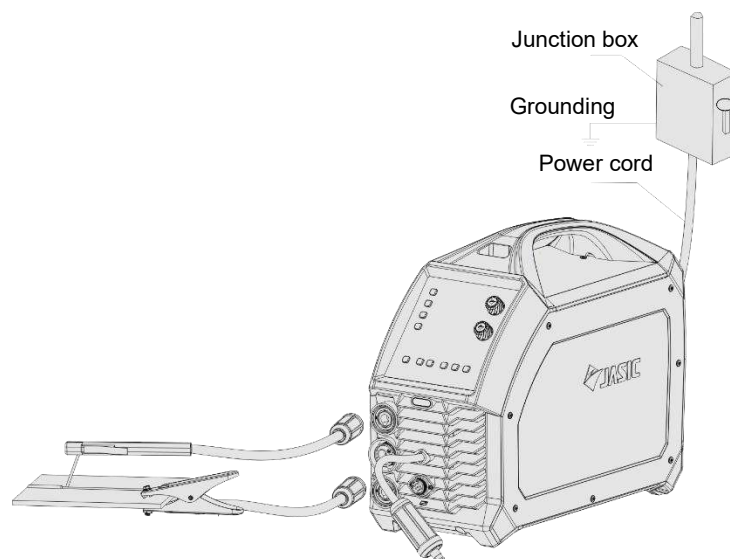

(Wiring diagram of MMA: DCEP)

Pay attention to the polarity of the wiring before MMA. Generally, there are two connection methods of DC welding: DCEN and DCEP.

DCEN: The electrode holder is connected to the negative polarity, and the workpiece is connected to the positive polarity;

DCEP: The electrode holder is connected to the positive polarity, and the workpiece is connected to the negative polarity.

The operator can also choose DCEN based on the base metal and electrode. Generally speaking, DCEP is recommended for basic electrodes (i.e., electrode connected to the positive polarity), while no special provisions are made for acid electrodes.

- 1) Ensure that the power switch of the welder itself is turned off.
- 2) Insert the cable plug with earth clamp into the corresponding socket on the front panel of the welder and tighten it clockwise.
- 3) Insert the cable plug with earth clamp into the corresponding socket on the front panel of the welder and tighten it clockwise.

NOTE! If you want to use long secondary cables (electrode holder and earth cable), you must ensure that the cross-sectional area of the cable is increased appropriately in order to reduce the voltage drop due to the cable length.

5.5. Lift TIG welding torch and earth cable connection

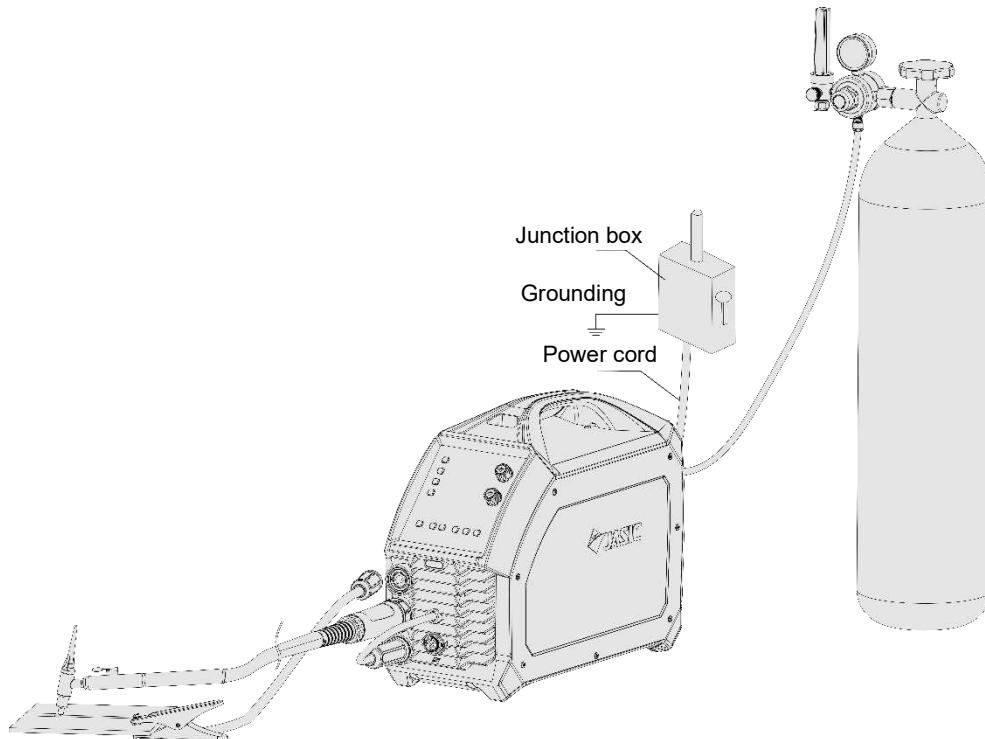

(Wiring diagram of Lift TIG: DCEN)

- 1) Ensure that the power switch is turned off.
- 2) Insert the torch plug into the central socket on the front panel of the welder and tighten it clockwise.
- 3) Insert the cable plug with earth clamp into the positive polarity socket on the front panel of the welder and tighten it clockwise.
- 4) Insert the polarity changeover connector into the negative polarity socket on the front panel of the welder and tighten it clockwise.

Note! The positive and negative polarities should not be reversed as this will prevent normal welding operation.

- 5) Connect one end of the gas hose to the gas valve inlet on the rear panel of the welder, and the other end to the gas regulator outlet, and secure it with a clamp.

NOTE! If you want to use long secondary cables (TIG torch cable and earth cable), you must ensure that the cross-sectional area of the cable is increased appropriately in order to reduce the voltage drop due to the cable length.

5.6. Wired handheld remote controller / foot pedal controller connection (optional)

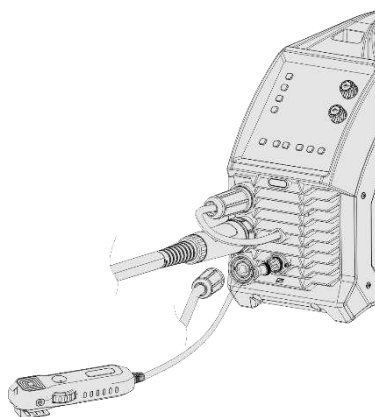

(Wiring diagram of wired remote controller)

Insert the 9-pin aviation plug of the handheld remote controller/foot pedal controller directly into the corresponding 9-pin aviation socket of the machine.

Note! Please check with the seller whether the hardware and software versions of the machine support wired handheld remote controller before installation.

5.7. Installation of wireless receiver module (optional)

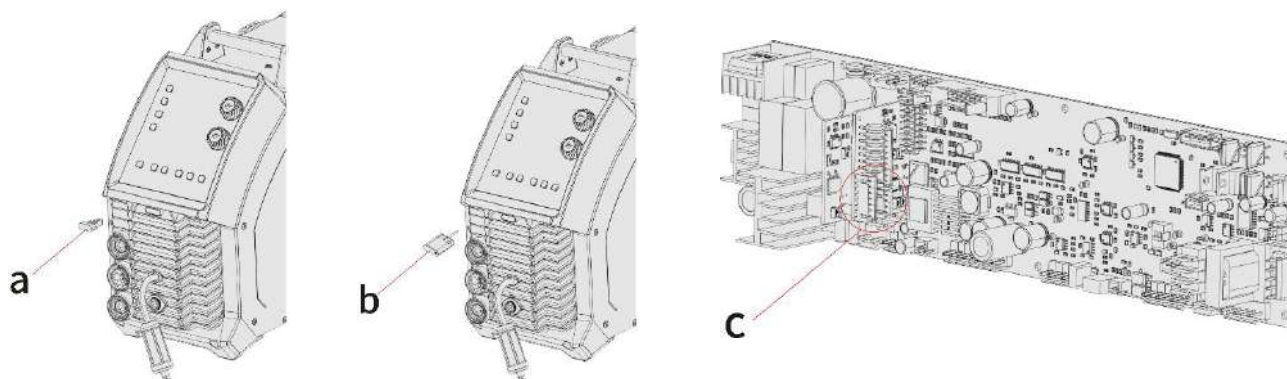

(Installation of wireless receiver module)

- 1) Remove the wireless remote controller plug cover shown in above left figure (a). Refit into the wireless receiver module shown in above right figure (b).
- 2) Remove the screws on the left side cover of the machine and remove the side panel.
- 3) Connect the cable of the wireless module to the 7P terminal block CN3 of the control board PCB2 (see c).

Note! Check with the seller whether the hardware and software versions of the machine support wireless remote controller before purchasing.

6. Control panel

6.1. Overview

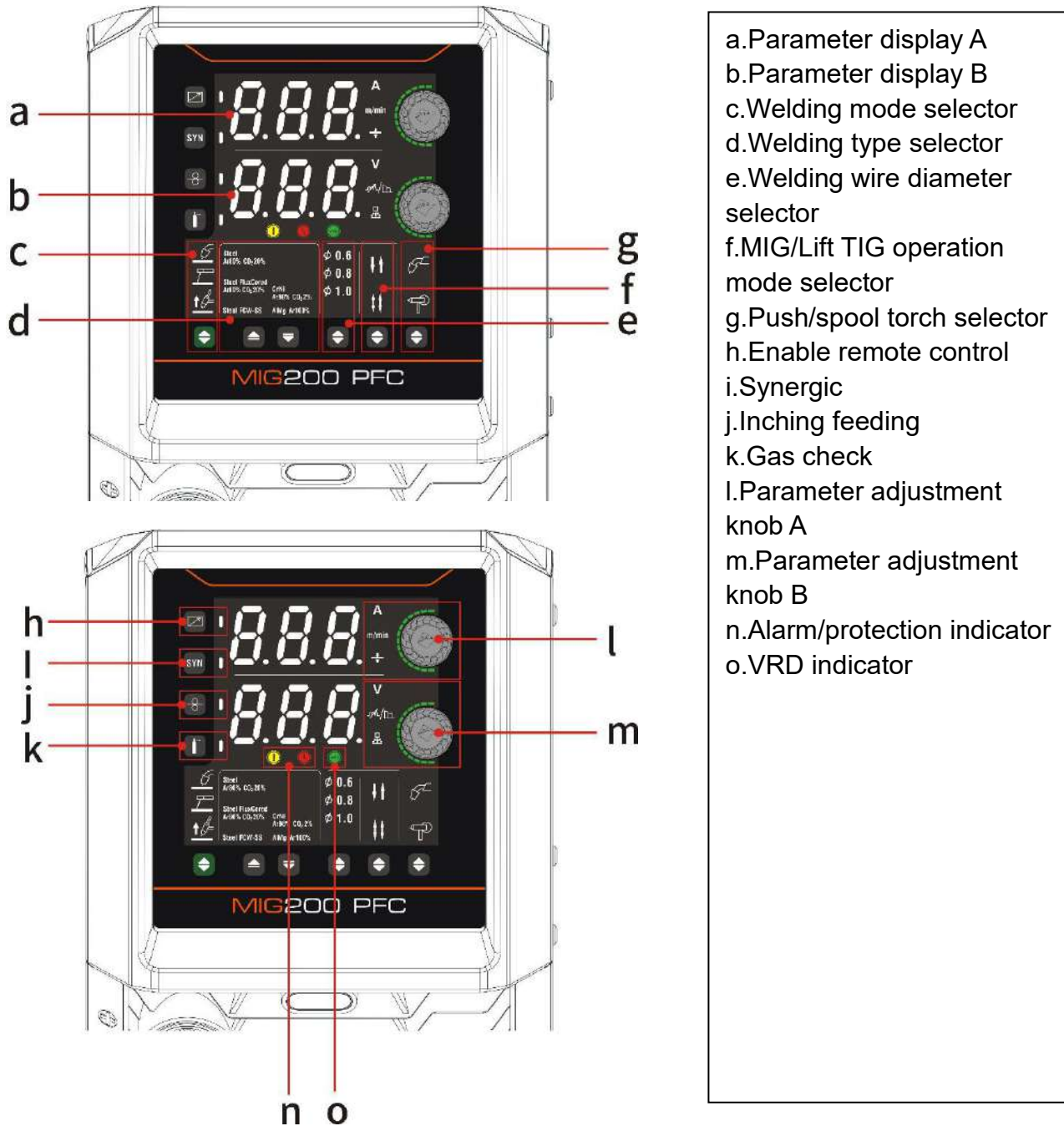

(OPERATOR PANEL)

Note! Some models do not support "h. Remote control function" and "g. Push/spool torch selector". Please confirm with the seller whether the machine supports relevant functions before purchasing.

a. Parameter display A



Parameter display A is used to display the current, wire feeding speed, and plate thickness parameters and error code.

- 1) When not welding, the preset value of current parameter will be displayed. If no operation is performed for a long time, the default parameters are displayed.
- 2) When welding, the actual output current value is displayed.
- 3) When the factory settings are restored, the countdown is displayed.
- 4) When the barcode queried, the machine barcode is displayed.
- 5) When the product is not working correctly, an error code is displayed.

In MIG Synergic mode, MMA mode or Lift TIG mode, current is displayed by default. If Synergic is disabled in MIG mode, the wire feed speed is displayed by default.

b. Parameter display B





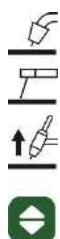

Parameter display B is used to display the voltage, inductance/arc force, and burn back time.

- 1) When not welding, the preset value of current parameter is displayed. If no operation is performed for a long time, the default parameters are displayed.
 - 2) When welding, the actual output voltage is displayed.
- The voltage is displayed by default in all welding modes.

c. Selection of welding mode



Before welding, press the "Welding Mode Selection" key  to switch among MIG, MMA and Lift TIG welding, and select the corresponding mode based on the welding process requirements.

- 1) If the indicator  is on, it indicates that MIG mode has been selected.
- 2) If the indicator  is on, it indicates that MMA mode has been selected.
- 3) If the indicator  is on, it indicates that Lift TIG mode has been selected.

Note! When the machine is welding or the torch trigger is pressed, the switching

function is unavailable.



d. MIG type selection

Steel
Ar80% CO₂20%

Steel FluxCored
Ar80% CO₂20% CrNi
Ar98% CO₂2%

Steel FCW-SS AlMg Ar100%



1) In MIG mode, press the welding type selection keys   to switch the welding type.

2) If the corresponding welding type indicator is on, it indicates that the welding type has been selected.

e. Selection of MIG welding wire diameter selection

φ 0.6
φ 0.8
φ 1.0
φ 1.2





1) In MIG mode, press the corresponding function switching key  to select an optional welding wire diameter for the welding type.

2) If the corresponding welding wire diameter indicator is on, it indicates that the welding wire diameter has been selected.

f. Selection of 2T/4T operation mode



1) In MIG or Lift TIG mode, press the corresponding function switching key  to select 2T or 4T operation mode.



2) If the indicator  is on, it indicates that the machine is in 2T operation mode.

3) If the indicator  is on, it indicates that the machine is in 4T operation mode.

g. Selection of push/spool torch



In MIG mode, press the corresponding function switching key  to select the push torch or spool torch.

- 1) If the indicator  is on, it indicates that the MIG is in push torch state.
- 2) If the indicator  is on, it indicates that the MIG is in spool torch state.

h. Selection of remote control function



Wired remote controller

1) Enter the Welding Engineer Mode (see section 6.4 for details), set the "F09" parameter to "1", save the settings and exit the mode.

2) Before welding, press the remote control function key  to enable/disable the remote control function.

3) If the indicator  is on, it indicates that the remote control function has been enabled. If it is off, it indicates that the remote control function has been disabled.

Wireless remote controller

1) Set the remote control mode to wireless remote controller

Enter the Welding Engineer Mode (see section 6.4 for details), set the "F09" parameter value to "0", save the settings and exit the mode.

2) Wireless pairing connection

When not welding, press and hold the panel remote control function button  and the

pairing button  of the wireless remote control at the same time, to pair the wireless

remote controller in 2 seconds. During pairing, the blue indicator  of the wireless



receiver module will flash. After successful pairing, the remote control mode indicator  will

be on, and the blue indicator  on wireless receiver module will remain on and the welder display window will display "OK".

After successful pairing, the parameters can be adjusted by the wireless remote controller.

3) Disconnecting the wireless connection

After the remote controller has been successfully paired, press and hold the remote control

function key  on the panel or the pairing key  on the wireless remote controller for 2 seconds, and the wireless connection of the remote controller will be disconnected.



After disconnecting, the display window of the welder will display "FAL", and the green

indicator  of the wireless receiver module will remain on.

Note: The icon of the pairing key may be different from the actual one due to different remote controller types. See the description of remote controller for specific operation.



i. MIG synergic function switching



- 1) In MIG mode, press the "Synergic" function key  to enable or disable the function.
- 2) If the indicator  is on, it indicates that the "Synergic" function is enabled. If it is off, it indicates that the function is disabled.
- 3) In "Synergic" mode, the machine automatically matches the welding parameters according to the current/wire feed speed/plate thickness + welding type + welding wire diameter settings.



j. Inching feeding function switching



- 1) In MIG mode, press the inching feeding key  to enable the function and release the key to disable it.
- 2) If the indicator  is on, it indicates that the inching feeding is enabled to start wire feeding, and the wire feed speed depends on the preset value.

k. Gas check function switching



- 1) In MIG mode, press the gas check function key  to enable or disable the function.
- 2) If the indicator  is on, it indicates that the gas check function is enabled and the gas valve is open.

Note: The gas check function automatically stops after 20s to avoid gas waste.

l. Parameter adjustment knob A

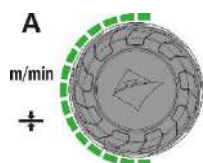

- 1) In MIG mode, if the "Synergic" function is disabled, the wire feed speed can be set. If the function is enabled, rotate the knob to switch display of current, wire feed speed and plate thickness for configuration.

- 2) In MMA or Lift TIG mode, the current parameter can be configured.
- 3) Rotate the adjustment knob to adjust the parameters.
- 4) Rotating the adjusting knob clockwise increases the parameter value, and rotating it counterclockwise decreases the value.
- 5) When the adjustment knob is rotated, the adjusted parameter is displayed in the parameter display area.

m. Parameter adjustment knob B

V

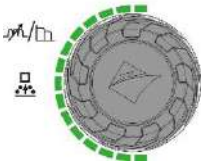

- 1) In MIG mode, rotate the knob to switch the display of voltage, welding inductance, and burn back time for configuration.
- 2) In MMA mode, rotate the knob to set the arc force for MMA welding.
- 3) Rotate the adjustment knob to adjust the parameters.
- 4) Rotating the knob clockwise increases the parameter value, while rotating it counterclockwise decreases the value.
- 5) When the adjustment knob is rotated, the adjusted parameter is displayed in the parameter display area.

n. Protection/alarm indicators



If the overheat indicator  is on, it indicates that the welder is in overheat protection and has stopped output.

Do not turn off the machine. Wait for a while, and then continue welding after the overheat indicator turns off.

If the overcurrent indicator  is on, it indicates that the welder is in overcurrent protection and has stopped output.

Please turn off and restart the machine. If this phenomenon persists, please contact professional maintenance personnel of the company.

o. VRD function indicator

- 1) When the VRD function is not enabled, the VRD indicator light is off.
- 2) If the VRD function is enabled and no welding is in process and the VRD indicator light displays green , it indicates that the VRD function is normal.
- 3) If the VRD function is enabled and no welding is in process and the VRD indicator light displays red , it indicates that the VRD function is abnormal.
- 4) When the VRD function is enabled, the VRD indicator is not on during welding.

6.2. Barcode display

1) Before welding, press and hold the "Welding Mode Selection" key  and "Parameter

Adjustment Knob A"  for 3s at the same time, and the machine barcode will be displayed.

2) Press any key or wait for 20s to exit the barcode display.

3) The barcode is displayed in nine groups of data in the "Parameter Display A" area, including "1.XY", "2.XY"..... to "9.XY", where X and Y are figures from 0-9. Refer to the following table for details:

Data displayed	Meaning
1.XY	X and Y represent the 1 st and 2 nd digits/letters of the digital barcode respectively
2.XY	XY represents the 3 rd digit/letter of the digital barcode, and YX is from 11-45, corresponding to the barcode D-Z and representing the year
3.XY	XY represents the 4 th digit/letter of the digital barcode, and YX is from 01-12, corresponding to the barcode 0-C and representing the month
4.XY	XY represents the 5 th digit/letter of the digital barcode, and YX is from 01-31, corresponding to the barcode 0-V and representing the date
5.XY	X and Y represent the 6 th and 7 th digits/letters of the digital barcode respectively
6.XY	X and Y represent the 8 th and 9 th digits/letters of the digital barcode respectively
7.XY	X and Y represent the 10 th and 11 th digits/letters of the digital barcode respectively
8.XY	X and Y represent the 20 th and 21 st digits/letters of the digital barcode respectively
9.XY	X and Y represent the 22 nd and 23 rd digits/letters of the digital barcode respectively

The 12th-19th digits in the digital barcode are the company's internal fixed numbers, which are not displayed in the window.

Read the nine groups of data and arrange them in order from left to right, skipping the 12th-19th digits, to get the barcode of the machine.

6.3. Restore factory settings

1) Before welding, press and hold the "Welding Mode Selection" key  for 5 seconds to restore factory settings.

2) After pressing and holding for 5 seconds, the display window will count down from 3.

When the countdown ends, the factory settings are restored. If the button is released before the countdown ends, the factory restore will not take place.

3) The factory settings are as shown in the following table:

Option	Parameter Name	Restored Parameter Value	Restored Parameter Value	Restored Parameter Value	Remarks
		MIG160 series	MIG200 series	MIG250 series	
MIG parameters	Burn back time	0.2S	0.2S	0.2S	
	Burn back voltage	13V	13V	13V	
	Inductance	0	0	0	
	Pre-flow time	0.1S	0.1S	0.1S	
	Post-flow time	0.5S	0.5S	0.5S	
	Welding voltage	19.0V	19.0V	19.0V	
	Wire feeding speed	5m/min	5m/min	5m/min	
	Crater voltage	19.0V	19.0V	19.0V	
	Crater feeding speed	5m/min	5m/min	5m/min	
MMA parameters	Arc-force current	40A	40A	40A	
	Hot start current	30A	30A	30A	
	Welding current	130A	130A	130A	
Lift TIG parameters	TIG downslope time	0.5S	0.5S	0.5S	
	Welding current	100A	100A	100A	

6.4. Welding engineer mode functions

The Welding Engineer Mode function allows users to set/modify the default parameters/functions as follows:

- 1) Press and hold "Parameter Adjustment Knob A" for 5s in startup state.
- 2) After pressing and holding the "Parameter Adjustment Knob" for 2s, the machine will count down from 3s; at the end of the countdown, "Parameter Display A" on the display window will display a parameter number, such as "F01". "Parameter Display B" on the display window will display the value corresponding to that number.
- 3) Rotate "Parameter Adjustment Knob A" to select the parameter number to set the back-end parameter/function.
- 4) Rotate "Parameter Adjustment Knob B" to set the value corresponding to that parameter number.
- 5) Press "Parameter Adjustment Knob A" to save the new value.
- 6) After setting the value, press Welding Method Selection key to exit the Welding Engineer Mode.
- 7) Refer to the following table for the parameter numbers, function definitions and configuration values

Back-end parameter/function	Parameter no.	Default value	Function definition
Response time of standby function	F01	10	Can be set to four values: "0", "5", "10" or "15". 1) "0" indicates that the standby function is disabled and the machine will not enter standby state. 2) "5", "10" and "15" indicate that the standby function is enabled and the machine will enter the standby state after the corresponding time (unit: minutes).
Input overvoltage/undervoltage protection	F02	Plus:0 Standard : 1	Can be set to "0" or "1". 1) "0" indicates that the overvoltage/undervoltage protection function is disabled. 2) "1" indicates that the overvoltage/undervoltage protection function is enabled. Note: The standard machine only provides input overvoltage function.
Pre-flow time	F03	MIG: 0.1 Lift TIG: 0.5	Set the MIG/Lift TIG welding parameters based on the "Welding Mode" when in Welding Engineer Mode. 1) If the "Welding Mode" is MIG, set the MIG pre-flow time, with range 0-2.0, accuracy of 0.1, and unit of seconds. If the "Welding Mode" is Lift TIG, set the Lift TIG pre-flow time, with range 0-5.0, accuracy of 0.5, and unit of seconds.

Post-flow time	F04	MIG: 0.5 Lift TIG: 5	Set the MIG/TIG welding parameters according to the "Welding Mode" when in Welding Engineer Mode . 1) If the "Welding Mode" is MIG, set the MIG post-flow time, with range 0-5.0, accuracy of 0.5, and unit of seconds. 2) If the "Welding Mode" is Lift TIG, set the Lift TIG post-flow time, with range 0-10.0, accuracy of 0.5, and unit of seconds.
Lift TIG downslope time	F05	0.5	Set the Lift TIG downslope time, with range 0-5, accuracy of 0.5, and unit of seconds.
Burn back voltage	F06	13	Set the MIG burn back voltage, with range 10-20, accuracy of 0.1, and unit of voltages.
Hot start current	F07	30	Set the MMA hot start current, with range 0-60, accuracy of 1, and unit of amperes.
Slow wire feed speed	F08	1	Set the slow wire feed speed of MIG; can be set to "0", "1", "2" or "3". 1) "0" indicates that the slow wire feed function is disabled. 2) "1", "2" or "3" indicate that the slow wire feed speed is 1/3, 1/2 or 2/3 of the current set speed, respectively.
Remote control mode	F09	0	Can be set to "0" or "1" to use wireless or wired remote controller. 1) "0" indicates wireless remote controller. 2) "1" indicates wired remote controller.

Note! If entering the Welding Engineering Mode from different "Welding Mode" states, the functional definition corresponding to the background parameters/functions may be also different! For example: If entering the Welding Engineering Mode background from the MIG welding mode, the pre-flow/post-flow time set are the pre-flow/post-flow time of MIG mode.

Note! Some models do not support F09. Please confirm with the seller whether the machine supports this function before purchasing.

7. Welding function operation



Warning! Before turning on the power supply make sure that the equipment is disconnected to the output. Otherwise, an unexpected arc may be started when the power is turned on. This can cause damage to the work piece and to personnel.



Warning! Be sure to wear appropriate protective equipment during welding or cutting operation. Arcs, spatter, smoke, and high temperatures produced in the process may cause injury to personnel.



Warning! After the power supply is turned off, the output voltage of the machine may continue for a period and then drop slowly. Please do not touch the conductive part of the output before the panel is extinguished.

7.1. MIG operation

NOTE! Some models are equipped with the smart fan function. When the power supply is turned on for a period before welding or cutting, the fan will automatically stop running. It will run automatically when welding or cutting begins.

7.1.1 Turn on the power switch

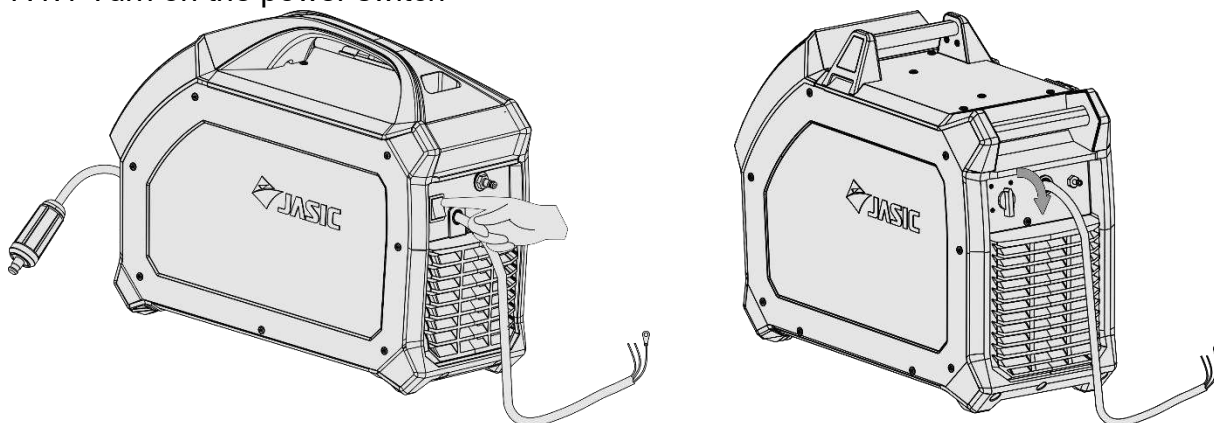

The power switch is located at the rear panel of the machine; set it in the "ON" position; then the panel indicator will light up, the fan will start to rotate, and the welder will start to work normally.

7.1.2 Select MIG mode



(MIG mode: Synergic enabled)

- 1) Press the "Welding Mode Selection" key to select MIG mode.
- 2) Use the corresponding function switching key to select the welding type, wire diameter, operation method and welding torch type.
- 3) Enable/disable the "Synergic" function.
- 4) Use "Parameter Adjustment Knob A/B" to set the welding parameters.

7.1.3 Set welding parameters with "Synergic" disabled



(Setting wire feed speed and voltage) (Setting inductance) (Setting burn back)

- 1) Use "Parameter Adjustment Knob A" to set the "Wire Feed Speed".
- 2) Use "Parameter Adjustment Knob B" to set the "Welding Voltage".
- 3) Press "Parameter Adjustment Knob B" to switch display of "Welding Voltage", "Welding Inductance", and "Burn Back Time" and set the parameter values.
- 4) The parameters that can be set on the panel and their ranges are as follows:

No.	Parameter Name	Parameter options or range (Input 230V _{AC})					
		MIG250P FC	MIG250	MIG200P FC	MIG200	MIG160P FC	MIG160
1	Wire feed speed (m/min)	2~18	2~18	2~15	2~15	2~14	2~14
2	Welding voltage (V)	11~30	11~30	11~28	11~28	11~26	11~26
3	Inductance	-10~10	-10~10	-10~10	-10~10	-10~10	-10~10

4	Burn back time (ms)	0~800	0~800	0~800	0~800	0~800	0~800
No.	Parameter Name	Parameter options or range (Input 115V _{AC})					
		MIG250P FC	MIG250	MIG200P FC	MIG200	MIG160P FC	MIG160
1	Wire feed speed (m/min)	2~13	/	2~13	/	2~11	/
2	Welding voltage (V)	11~25	/	11~24	/	11~22	/
3	Inductance	-10~10	/	-10~10	/	-10~10	/
4	Burn back time (ms)	0~800	/	0~800	/	0~800	/

7.1.4 Set welding parameters with Synergic enabled



(Setting welding current) (Setting wire feed speed) (Setting plate thickness)

- 1) Press "Parameter Adjustment Knob A" to switch display of "Welding Current", "Wire Feed Speed", and "Plate Thickness" and set the parameter values.
- 2) The welder automatically matches the other welding parameters according to the built-in Synergic expert library to achieve good welding results.
- 3) Press "Parameter Adjustment Knob B" to switch display of "Welding Voltage", "Welding Inductance", and "Burn Back Time" and adjust the parameter values.

7.1.5 Use of digital torch or spool torch (optional)

In addition to the common push torch, these inverter welders also support digital MIG torch and spool torch. The parameters are adjusted through the keys on the digital torch or the adjustment knob on the spool torch.

1) Digital torch

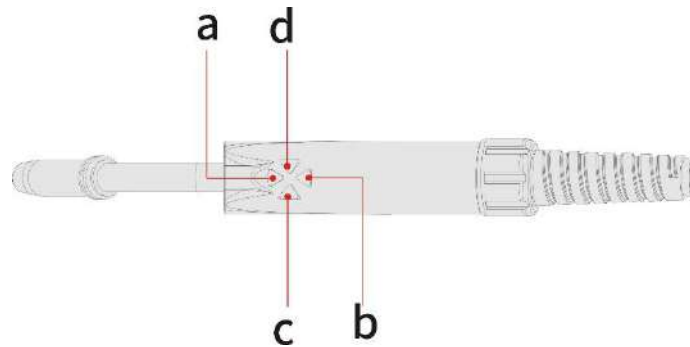

a. Increase the "Wire Feed Speed"/"Welding Current".

b. Decrease the "Wire Feed Speed"/"Welding Current".

The "Wire Feed Speed"/"Welding Current" adjustment key adjusts "Wire Feed Speed" when the "Synergic" is disabled, and "Welding Current" when it is enabled.

c. Increase the "Welding Voltage".

d. Decrease the "Welding Voltage".

1) After connecting the digital torch with the welder, select "Push Torch" of the welding torch type.

2) Enable the remote control function.

3) Use the keys on the digital torch to adjust the "Wire Feed Speed"/"Welding Current" and "Welding Voltage". For details about panel operations, see sections 7.12-7.14.

Note! If the digital torch is used, select the welding torch type of "Push torch". The parameters can be adjusted by both the adjustment knobs on the operation panel and adjustment keys on the digital torch.

Note! Some models do not support spool torch function. Please confirm with the seller whether the machine supports this function before purchasing.

2) Spool torch

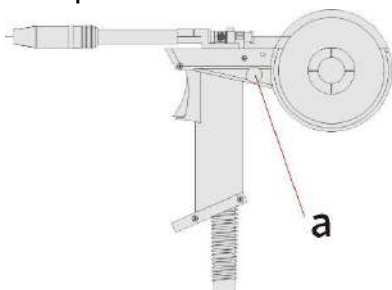

a. "Wire Feed Speed" adjustment potentiometer: Rotate the potentiometer clockwise to increase the "Wire Feed Speed", and counterclockwise to decrease the speed.



(Select spool torch)

- 1) After connecting the spool torch with the welder, select the "Spool Torch" mode of the welding torch type.
- 2) When the remote control function is enabled, the "Wire Feed Speed" is adjusted by the potentiometer of spool torch.
- 3) When the remote control function is disabled, the "Wire Feed Speed" is adjusted by the "Parameter Adjustment Knob A" on the operation panel of welder.
- 4) For details about other panel operations, see sections 7.12-7.14.

Note! The "Synergic" function is disabled when using the "Spool Torch" mode.

If there is no potentiometer on the spool torch, the "Spool Torch" is selected and the remote control function is enabled, the current will be unable to be adjusted.

Note! Some models do not support spool torch function. Please confirm with the seller whether the machine supports this function before purchasing.

7.1.6 Start welding

Description of MIG 2T/4T operation

2T operation mode

Step 1: Press the torch trigger to start welding.

Step 2: Release the trigger to stop welding.

4T operation mode

Step 1: Press the torch trigger for the first time to start welding.

Step 2: Release the trigger for the first time to continue welding.

Step 3: Press the trigger for the second time to resume welding.

Step 4: Release the trigger for the second time to stop welding.

Welding sequence of MIG 2T/4T operation

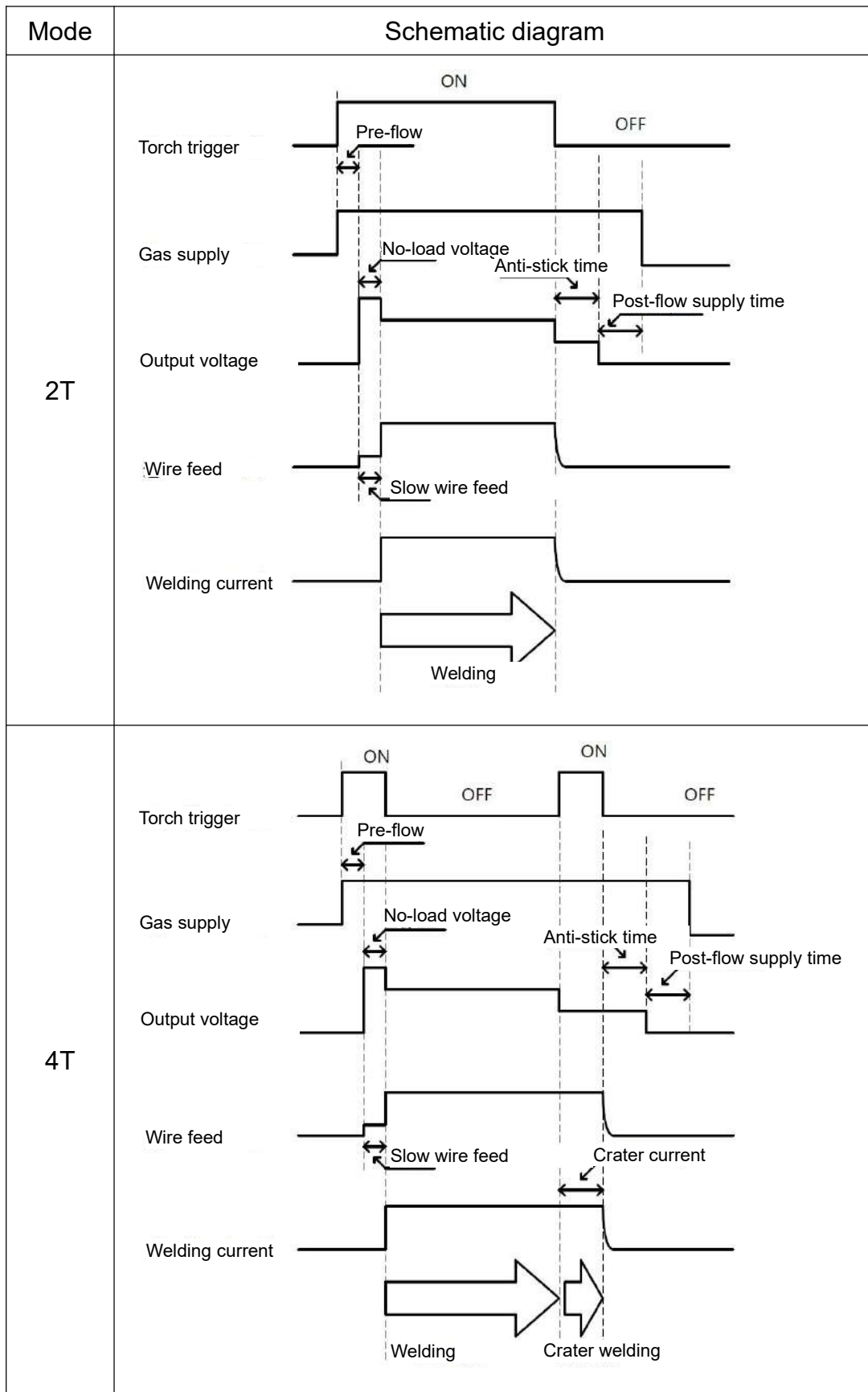

7.1.7 Turn off the power supply after welding

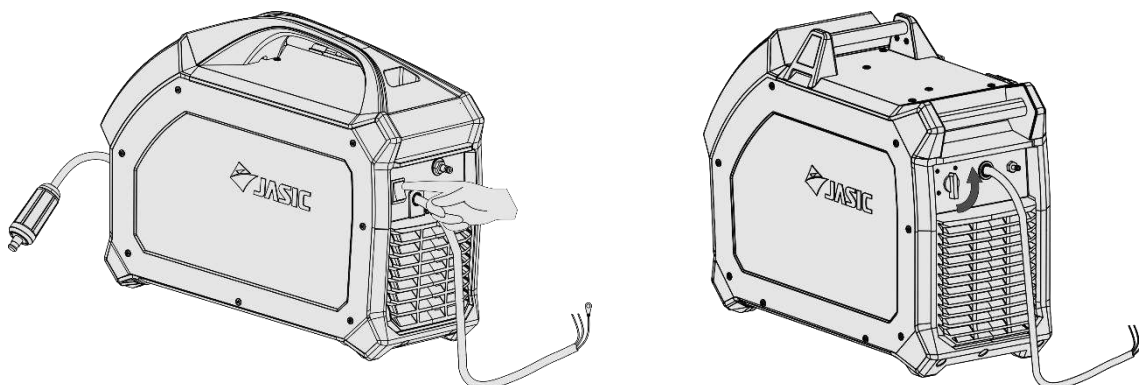

The power switch is located on the rear panel of the machine and set it to the "OFF" position. After a time delay, the panel indicator is off and the welder stops working.

7.2. MMA operation

7.2.1 Turn on the power switch (Same as 7.1.1)

7.2.2 Select welding mode



(Setting MMA welding current) (Setting arc force)
Press the "Welding Mode Selection" key to select MMA mode.

7.2.3 Set MMA parameters

- 1) Use "Parameter Adjustment Knob A" to set the "Welding Current".
- 2) Use "Parameter Adjustment Knob B" to set the "Arc Force".

Welding current: set by the user based on the type and diameter of the welding electrode and the process requirements. Refer to the following table:

No.	Electrode diameter (mm)	Electrode diameter (mm)	Welding current (A)
1	1.6	1.6	25~40

2	2.0~3.2	2.0	40~65
		2.5	50~80
		3.2	100~130
3	3.2~4.0	3.2	100~130
		4.0	160~210
4	≥5	5.0	200~270
		6.0	220~300

NOTE! The operator should set the functions that meet the welding requirements. If the selections are incorrect, this may lead to problems such as an unstable arc, spatter, or sticking of the electrode to the work piece.

Arc force: The arc force value should be determined according to electrode diameter, current setting, and process requirements. With large arc force current, the metal transfers quickly and the droplets don't stick, but excessive force increases spatter; low arc force leads to small spatter and good weld seam formation, but sometimes the arc is soft, or causes droplets to stick. In particular, thick electrodes with low current welding require increased arc force. Generally, the arc force is 0-40 when welding.

Hot start current: Stronger hot start current is conducive to arc start and reduces sticking between the welding electrode and workpiece during arc start. Set to 30A by default.

No.	Parameter Name	Setting range of "Arc Force" and "Hot Start Current"					
		MIG250PF C	MIG250	MIG200P FC	MIG200	MIG160P FC	MIG160
1	Arc force	0~100A					
2	Hot start current	Preset to 30A (0-60A available on user menu)					

During DC welding the heat on the positive and negative polarities of the welding arc is different. When welding using DC power supply, there are DCEN and DCEP connections. The DCEN connection refers to the welding electrode connected to the negative polarity of the power supply and the workpiece connected to the positive polarity of the power supply. In this mode the workpiece receives more heat, resulting in high temperature, deep penetration, easy to weld through, suitable for welding thick parts. The DCEP connection refers to the welding electrode connected to the positive polarity of the power supply and the workpiece connected to the negative polarity of the power supply. In this mode the workpiece receives less heat, resulting in low temperature, shallow pool, and less penetration. This is suitable for welding thin parts.

7.2.4 Start welding

NOTE! This unit has anti-stick function by default. In the welding process, if short circuit occurs for 1s, it will automatically enter anti-stick function. This means the welding current will automatically drop to 20A to allow the short circuit to be cleared. When the short circuit is cleared, the welding current will automatically return to the set current.

7.2.5 Turn off the power supply after welding

(Same as section 7.1.7)

The power switch is located on the rear panel of the machine and set it to the "OFF" position. After a time delay, the panel indicator is off and the welder stops working.

7.3. Lift TIG operation

7.3.1 Turn on the power switch

(Same as section 7.1.1)

7.3.2 Select Lift TIG welding mode



(Lift TIG mode)

Press the "Welding Mode Selection" key to select Lift TIG mode.

7.3.3 Set welding parameters

Use "Parameter Adjustment Knob A" to set the "Welding Current".

Choose the appropriate welding current, tungsten electrode and shielding gas flow based on the actual situation. For details, refer to the following data.

Selection of parameters for manual TIG welding – stainless steel plate

Tungsten diameter (mm)	Thickness of stainless steel plate (mm)	Maximum current (A)	Maximum argon flow rate (l/min)
1~2	1~3	50	5
		50~80	6
2~4	3~6	80~120	7
		121~160	8
		161~200	9
		201~300	10

7.3.4 Start welding

Description of MIG 2T/4T operation

2T operation mode

Step 1: Press the torch trigger to start welding.

Step 2: Release the trigger to stop welding.

4T operation mode

Step 1: Press the torch trigger for the first time to start welding.

Step 2: Release the trigger for the first time to continue welding.

Step 3: Press the trigger for the second time to resume welding.

Step 4: Release the trigger for the second time to stop welding.

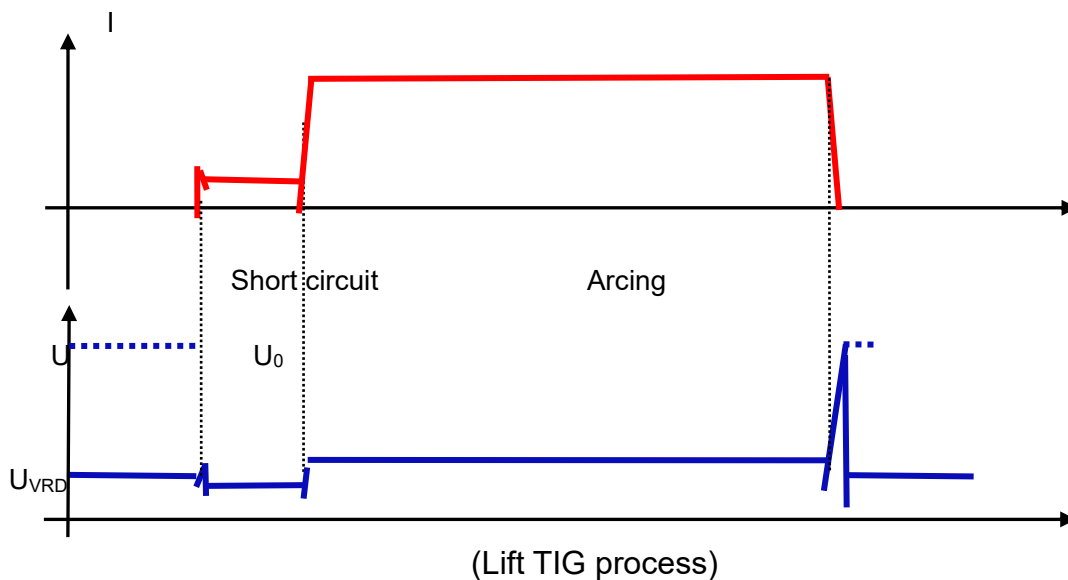

Note! When starting arc, the short-circuit time exceeds 2s, the welder turns off the output current, and it is necessary to lift the welding torch and short-circuit the tungsten electrode and workpiece again before starting arc again.

Note! In the welding process, if there is short circuit between tungsten electrode and workpiece, the welder will immediately reduce the output current; if the short circuit time exceeds 1s, the welder will turn off the output current, and the welding torch needs to be lifted to start the arc again.

7.3.4 Turn off the power supply after welding

(Same as section 7.1.7)

7.4. Standby



(Standby state interface)

- 1) Enter standby state: In both MIG and Lift TIG modes, the machine will enter standby state and close the display window in the operation panel if there are no welding or panel operations for a long time. The default standby response time is 10 minutes.
- 2) Exit standby state: In standby state, any operation on the welder will cause it to exit standby state, including welding, key/knob operation, pressing the torch trigger, or operating the paired and valid remote controller, etc.
- 3) For safety and convenience, the machine will not enter standby state in MMA mode.

7.5. Functions and use of wireless/wired remote controller

If the machine supports the remote control function and is equipped with a remote controller and accessories, the user can use the handheld remote controller or foot pedal controller to perform simple welding parameter adjustments at a distance after basic configuration on the machine operation panel.

For details, refer to the instructions for remote controller.

8. Maintenance



Warning!

The following operation requires sufficient professional knowledge on electric aspects and comprehensive safety knowledge. Make sure the input cable of the machine is disconnected from the electricity supply and wait for 5 minutes before removing the machine covers.

Please note: The following should only be carried out by an authorised electrical technician.

8.1. Power supply maintenance

In order to guarantee that the machine works efficiently and in safety, it must be maintained regularly. Operators should understand the maintenance methods and means of the machine operation. This guide should enable customers to carry out simple examination and safeguarding by oneself, try to reduce the fault rate and repair times of the machine, so as to lengthen service life of the machines.

<u>Period</u>	<u>Maintenance item</u>
Daily examination	Check the condition of the machine, mains cables, welding or cutting cables and connections. Check for any warnings LEDs and machine operation.
Monthly examination	Disconnect from the mains supply and wait for at least 5 minutes before removing the cover. Check internal connections and tighten if required. Clean the inside of the machine with a soft brush and vacuum cleaner. Take care not to remove any cables or cause damage to components. Ensure that ventilation grills are clear. Carefully replace the covers and test the unit. This work should be carried out by a suitably qualified competent person.
Yearly examination	Carry out an annual service to include a safety check in accordance with the manufacturers standard (EN 60974-1). This work should be carried out by a suitably qualified competent person.

9. Troubleshooting



Warning! Before machines are dispatched from the factory, they have already been checked thoroughly. The machine should not be tampered with or altered. Maintenance must be carried out carefully. If any wire becomes loose or is misplaced, it maybe potentially dangerous to user! Only professional maintenance personnel should repair the machine!

Ensure the power is disconnected before working on the machine. Always wait 5 minutes after power switch off before removing the panels.

9.1. Common malfunction analysis and solution



The symptoms listed here may be related to the accessories, gas, environmental factors, and power supply you use. Please try to improve the environment and avoid such situations.

Elimination of general problems in MIG

Symptom		Reasons	Troubleshooting
After startup, the fan does not turn or the wire feeding speed is abnormal		The ambient temperature is too low or the fan has been damaged	If the temperature is too low, let the machine work for a period of time, and the temperature in standby will rise and it will rotate normally. If it is still not working, replace the fan
MIG	The welder has no current output and has no error code display	<ul style="list-style-type: none"> · The welding circuit has failed · A component inside the welder has failed 	<ul style="list-style-type: none"> · Check the welding circuit and repair it · Contact the customer-service personnel and seek professional assistance
	After pressing the torch trigger to supply gas, there is current output but no wire feeding	<ul style="list-style-type: none"> · The wire feeder is stuck · The wire feeding motor has failed · The control board inside the welder has failed 	<ul style="list-style-type: none"> · Loosen the wire feeder · Replace the wire feeding motor · Replace the control board

	<p>The welding current is unstable and the current fluctuates</p>	<ul style="list-style-type: none"> · The torque knob of the wire feeder is not adjusted properly · The wire feed roller and welding wire are configured differently · The contact tip is seriously worn out · The liner in the welding torch is seriously worn out · The welding wire is of poor quality 	<ul style="list-style-type: none"> · Properly adjust the torque knob of the wire feeder · Match the wire feed roller with the welding wire · Replace the contact tip of the welding torch · Replace the liner in the welding torch · Replace with qualified welding wire
<p>Other faults</p>			<p>Please contact the maintenance personnel of JASIC Technology Co. Ltd</p>

Elimination of general problems in MMA

Symptom		Reasons	Troubleshooting
<p>After startup, the fan does not turn, or the speed is abnormal</p>		<p>The air temperature is too low, or the fan is damaged</p>	<p>When the temperature is too low, leave the machine work for a while. The temperature in standby will rise the fan and resume normal operation. If it is still not working, it is necessary to replace the fan.</p>
MMA	<p>Cannot start normal arc</p>	<p>The power cord is not connected properly</p>	<p>Connect the power cord</p>
	<p>Welding slag is difficult to remove</p>	<p>Low arc force</p>	<p>Increase the arc force</p>
	<p>Hot electrode holder</p>	<p>The rated current of the electrode holder is too low</p>	<p>Change the electrode holder with a higher current one</p>
	<p>Arc is easily interrupted</p>	<p>Low mains voltage</p>	<p>Use after the mains power is normal</p>
<p>Other faults</p>			<p>Please contact the maintenance personnel of JASIC Technology Co. Ltd</p>

Elimination of general problems in Lift TIG

Symptom		Reasons	Troubleshooting
After startup, the fan does not turn or the speed is abnormal		The ambient temperature is too low or the fan has been damaged	When the temperature is too low, leave the machine work for a while. The temperature in standby will rise the fan and resume normal operation. If it is still not working, it is necessary to replace the fan.
TIG	No current output when torch trigger is pressed	Some Lift TIG modes allow welding to end when the torch trigger is pressed	Release the torch trigger and start over
		Welding circuit is open	Check the welding circuit and reconnect it
	Rapid tungsten electrode burnout	Welding torch is connected to the wrong polarity	Switch the two plug positions
	Blackening of solder joints	Welds are not effectively protected and oxidized	(1) Ensure that the valve of argon cylinder is open and there is enough pressure. Generally, if the cylinder pressure is lower than 0.5 MPa, it must be refilled. (2) Check whether the argon flow rate is normal. You can select the flow rate according to the welding current condition, but too low a flow rate may lead to insufficient shielding gas to cover all weld joints. It is suggested that the argon flow rate be no less than 5L/min, no matter how small the current. (3) Check whether the gas path is leaking, or whether the gas purity is too low. (4) Check whether there is strong ambient air flow in the environment.
	Arc is hard to start and easily interrupted	Poor quality or serious oxidation of tungsten electrode	· Replace tungsten grade with better quality. · Grind off the tungsten oxide layer.

	Unstable current in welding process	The voltage of the power grid fluctuates seriously or the joint contact with the power grid is poor. Serious interference from other electrical equipment.	<ul style="list-style-type: none"> · Check whether the power grid is normal and connect the power connector. · Use different power cords to connect equipment that could seriously interfere with welder.
Other faults		Please contact the maintenance personnel of JASIC Technology Co. Ltd	

9.2. Alarm and solutions

Error code	Category	Possible cause	Countermeasure
E10	Overcurrent protection	Continuously output the maximum capacity current of welder	Restart the welder. If it is still in overcurrent protection, contact the after-sales department of the company.
E31	Undervoltage protection	Input network voltage is too low	Turn it off and on again. If this the alarm cannot be eliminated and the grid voltage remains too low, check the power grid voltage and wait for the grid to be normal before welding. If the grid voltage is normal and the alarm persists, contact professional maintenance personnel.
E32	Overvoltage protection	Input network voltage is too high	Turn it off and on again. If the alarm cannot be eliminated and the grid voltage remains too high, check the power grid voltage and wait for the grid to be normal before welding. If the grid voltage is normal and the alarm persists, contact professional maintenance personnel.
E34	Undervoltage protection	Undervoltage in the driver	Turn it off and on again. If the alarm cannot be eliminated, contact professional maintenance personnel.
E60	Overheat	Inverter IGBT temperature is too high	Do not turn off the machine. Wait for a while, and then continue welding after the indicator goes out.
E61	Overheat	Output rectifier diode is too hot	Do not turn off the machine. Wait for a while, and then continue welding after the indicator goes out.
	Abnormal VRD	No-load voltage is too high	Turn it off and on again. If the alarm cannot be eliminated, contact professional maintenance personnel.

Note! After applying the above countermeasures, the alarm still cannot be lifted or reappears after lifting. Please contact professional maintenance personnel.

9.3. Common MIG malfunction

When the welding conditions do not meet the requirements, the phenomena described in the following table will occur:

Table 9.3 Common MIG malfunction

Unsuitable Welding Condition	Result	Unsuitable Welding Condition	Result
The wire stick-out is too long	The arc is unstable, resulting in welding spatter.	The arc voltage is too high	The arc is too long and the fusion spatter increases.
	The bead becomes narrow		The welding bead becomes wider.
	The gas protection result is reduced, resulting in gas pores.		The arc is unstable.
The wire stick-out is too short	The nozzle is blocked, resulting in gas pores.	The arc voltage is too low	The arc is broken, the wire wanders, and welding spatter is generated.
	It affects the line of sight, making it difficult to observe the penetration.		The welding bead becomes narrow and the electrode is not melted.
	The thin base metal is easily burned through.		More excess weld metal and weld flushes.
The welding current is too high	The welding spatter increases.	The wire feeding speed is too high	The welding bead becomes narrow.
	The depth of penetration and excess weld metal increase and weld formation is poor.		The depth of penetration and excess weld metal decreases.
	The base metal is easy to burn through.		
Wire extension: refers to the distance between the contact tip of welding torch and workpiece to be welded			

10. Packaging, transportation, storage and waste disposal

10.1. Transportation requirements

In the process of handling the equipment, it should be handled with care, and should not be dropped or severely impacted. Avoid moisture and rain during transportation.

10.2. Storage conditions

Storage temperature: $-25\text{ }^{\circ}\text{C} \sim +50\text{ }^{\circ}\text{C}$

Storage humidity: relative humidity $\leq 90\%$

Storage period: 12 months

Storage site: indoors with no corrosive gas and air circulation

10.3. Waste disposal

Disposal

The equipment is manufactured with materials, which do not contain any toxic or poisonous materials dangerous to the operator.

When the equipment is scrapped, it should be dismantled separating components according to the type of materials.

Do not dispose of the equipment with normal waste. The European Directive 2002/96/EC on Waste Electrical and Electronic Equipment states the electrical equipment that has reached its end of life must be collected separately and returned to an environmentally compatible recycling facility.

In order to comply with WEEE regulations in your country you should contact your supplier.

RoHS Compliance Declaration

We herewith confirm, that the above mentioned product does not contain any of the restricted substances as listed in EU Directive 2011/65/EC in concentrations above the limits as specified therein.

Disclaimer: Please note that this confirmation is given to the best of our present knowledge and belief. Nothing herein represents and/or may be interpreted as warranty within the meaning of the applicable warranty law.

11. After-sales service

11.1. Warranty card

Each welder includes a warranty card. Please fill in the relevant information.
Read and keep the warranty card carefully.

11.2. Maintenance

Perform preliminary troubleshooting or record faults according to the common malfunction analysis and solution checklist. To repair or replace the device, contact a local dealer. Please use accessories or consumables provided by Shenzhen JASIC Technology Co., Ltd.
The warranty of this machine is subject to the date of sale on the warranty card or sales contract. Any faults caused by irregular or unreasonable use are not covered by the warranty and will be charged for repair.

Appendixes

Appendix 1: Wiring diagram

Wiring diagram 1 - MIG160/MIG200

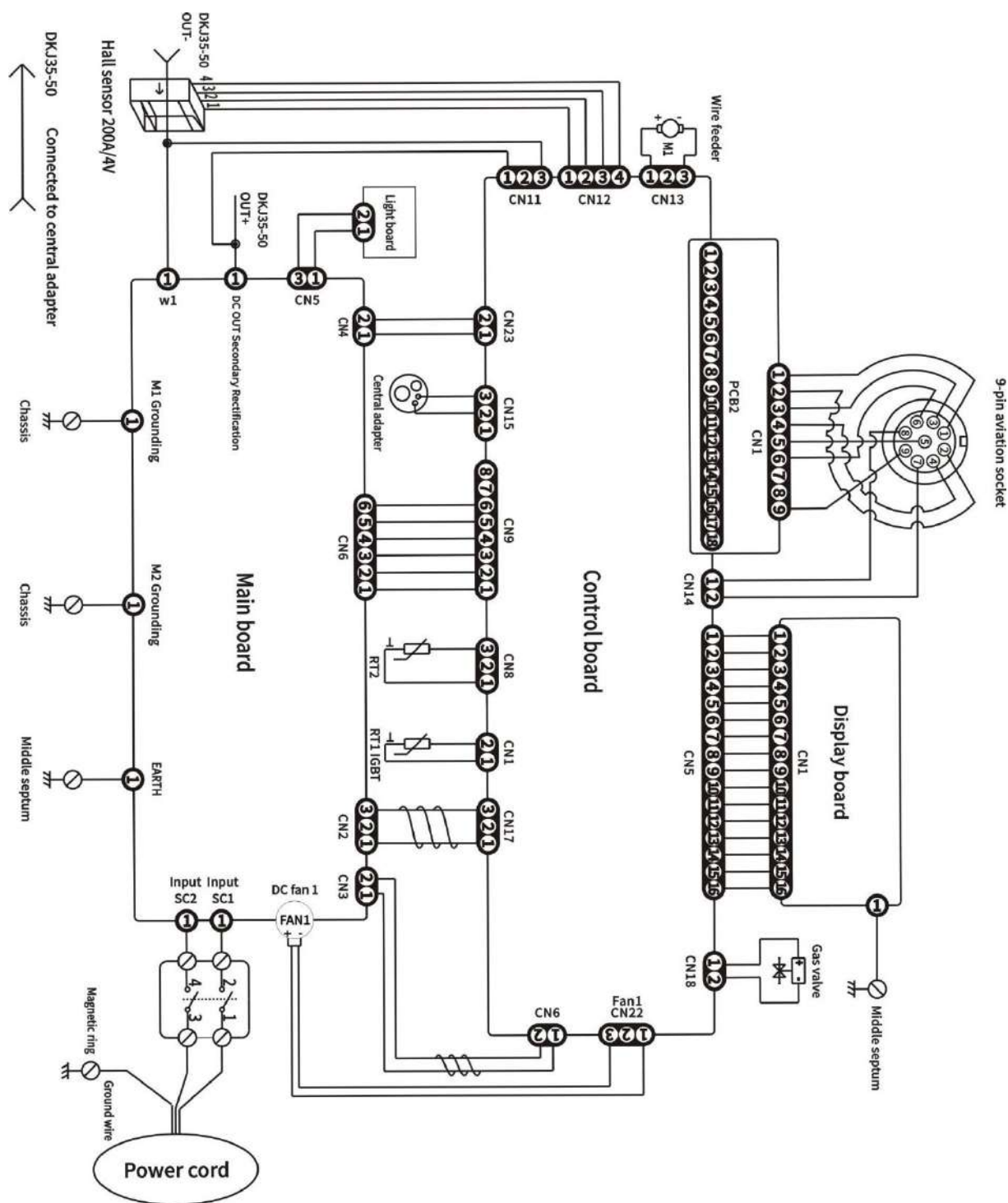

Note! Some models do not support PCB2 and 9-pin aviation socket. Please confirm with the seller whether the machine supports this function before purchasing.

Wiring diagram 2 - MIG160PFC/MIG200PFC

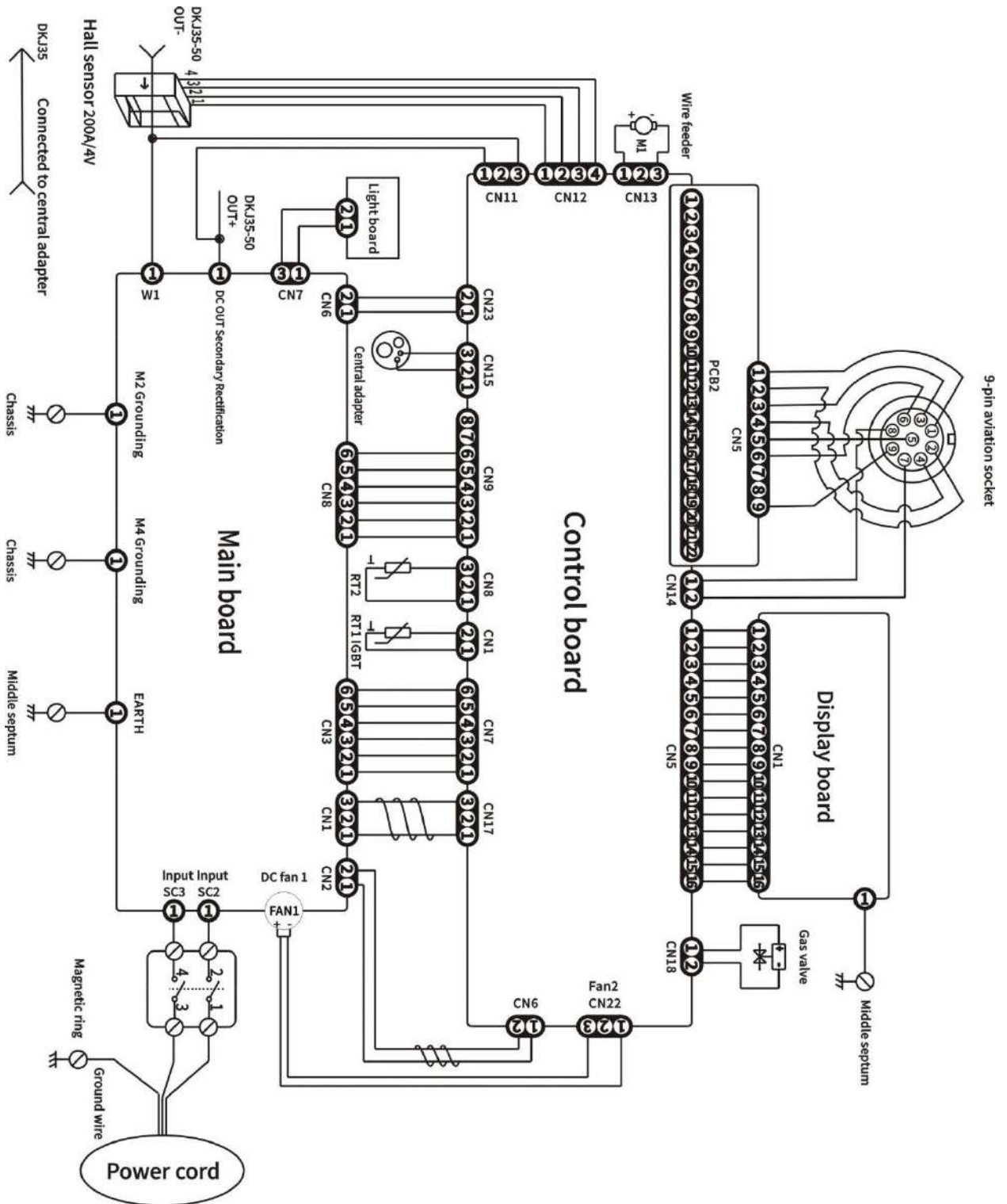

Note! Some models do not support PCB2 and 9-pin aviation socket. Please confirm with the seller whether the machine supports this function before purchasing.

Wiring diagram 3 - MIG250

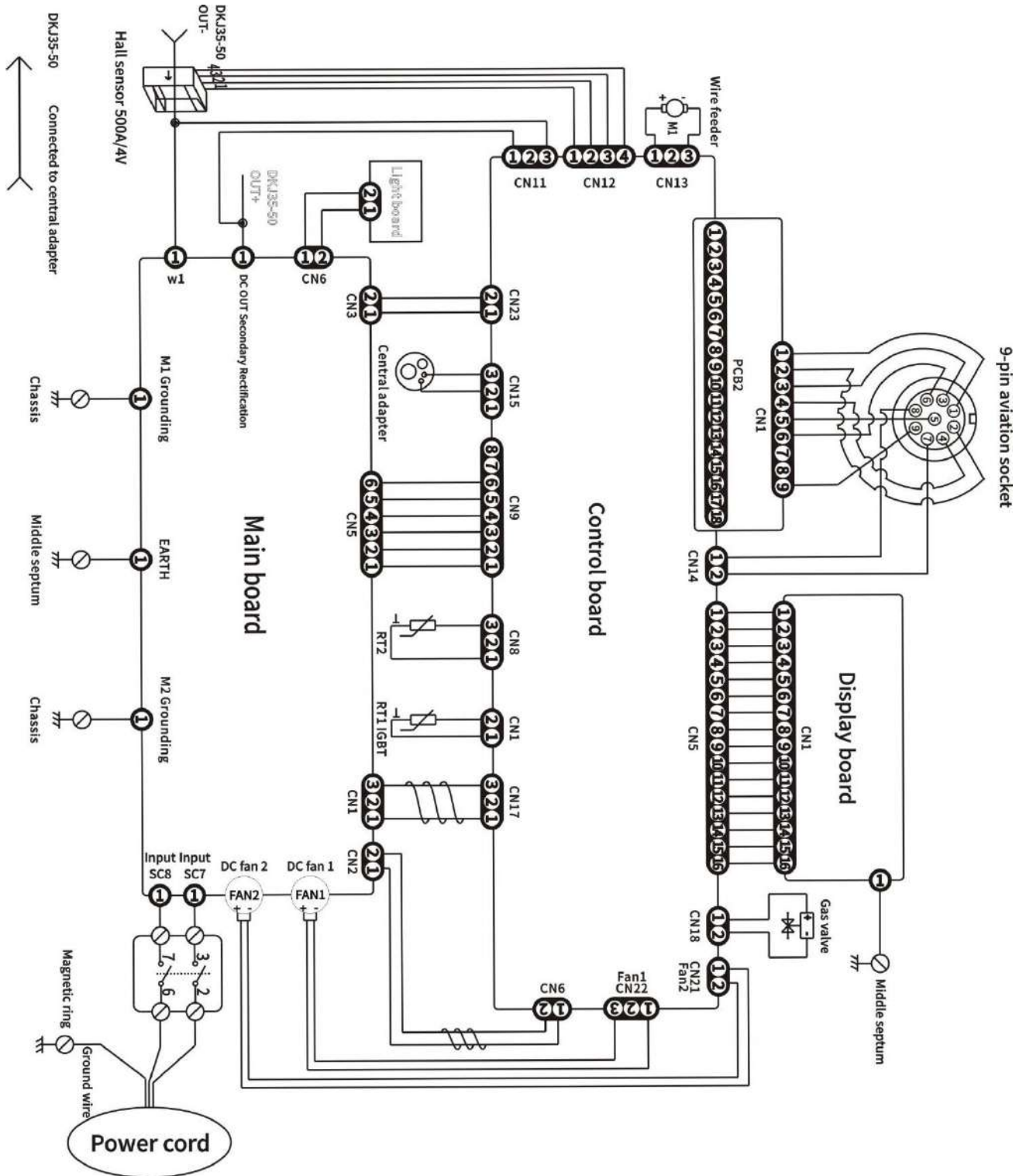

Note! Some models do not support PCB2 and 9-pin aviation socket. Please confirm with the seller whether the machine supports this function before purchasing.

Wiring diagram 4 - MIG250PFC

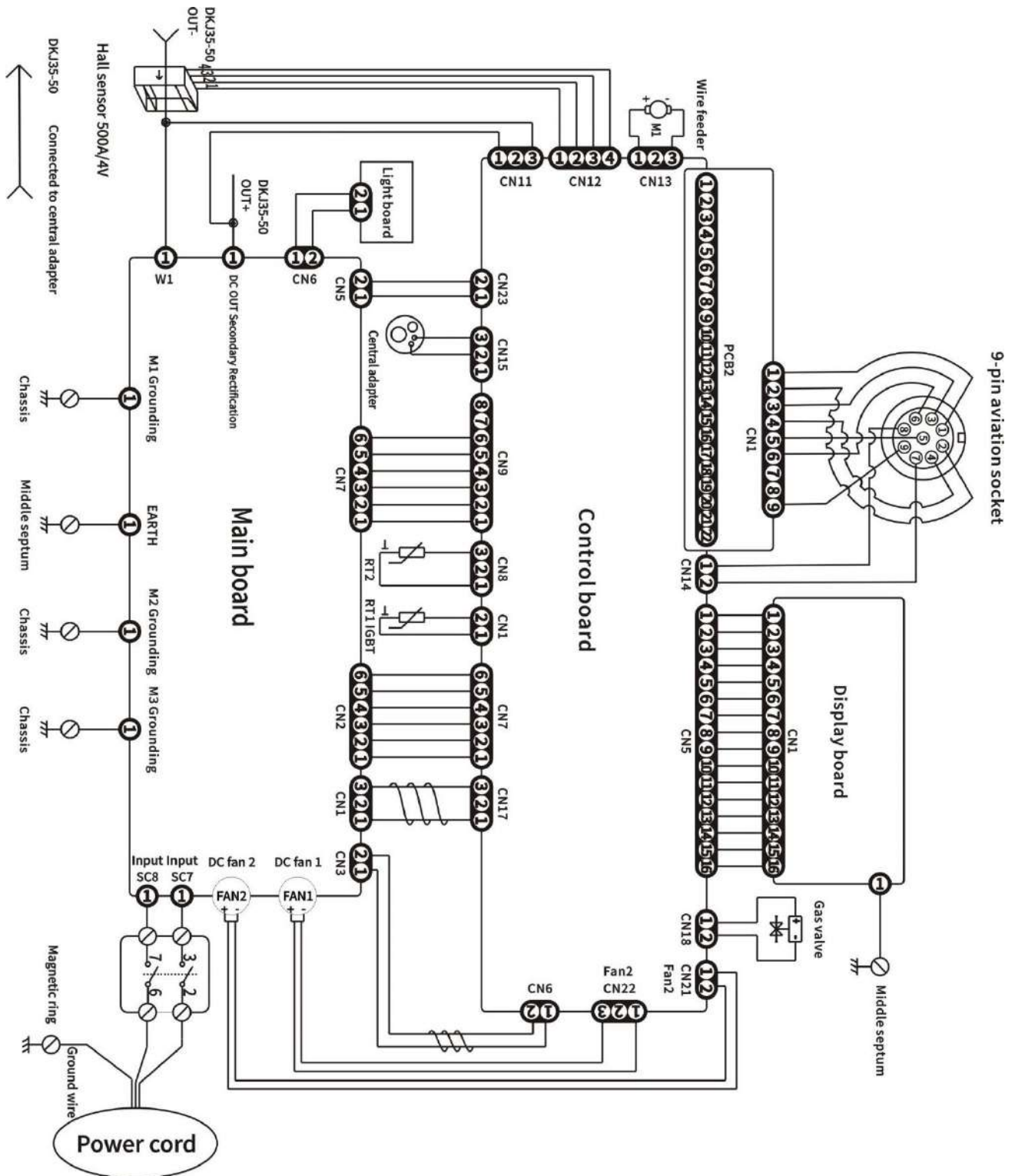

Note! Some models do not support PCB2 and 9-pin aviation socket. Please confirm with the seller whether the machine supports this function before purchasing.

Appendix 2: List of common spare parts

List of common spare parts 1 - MIG160/MIG200

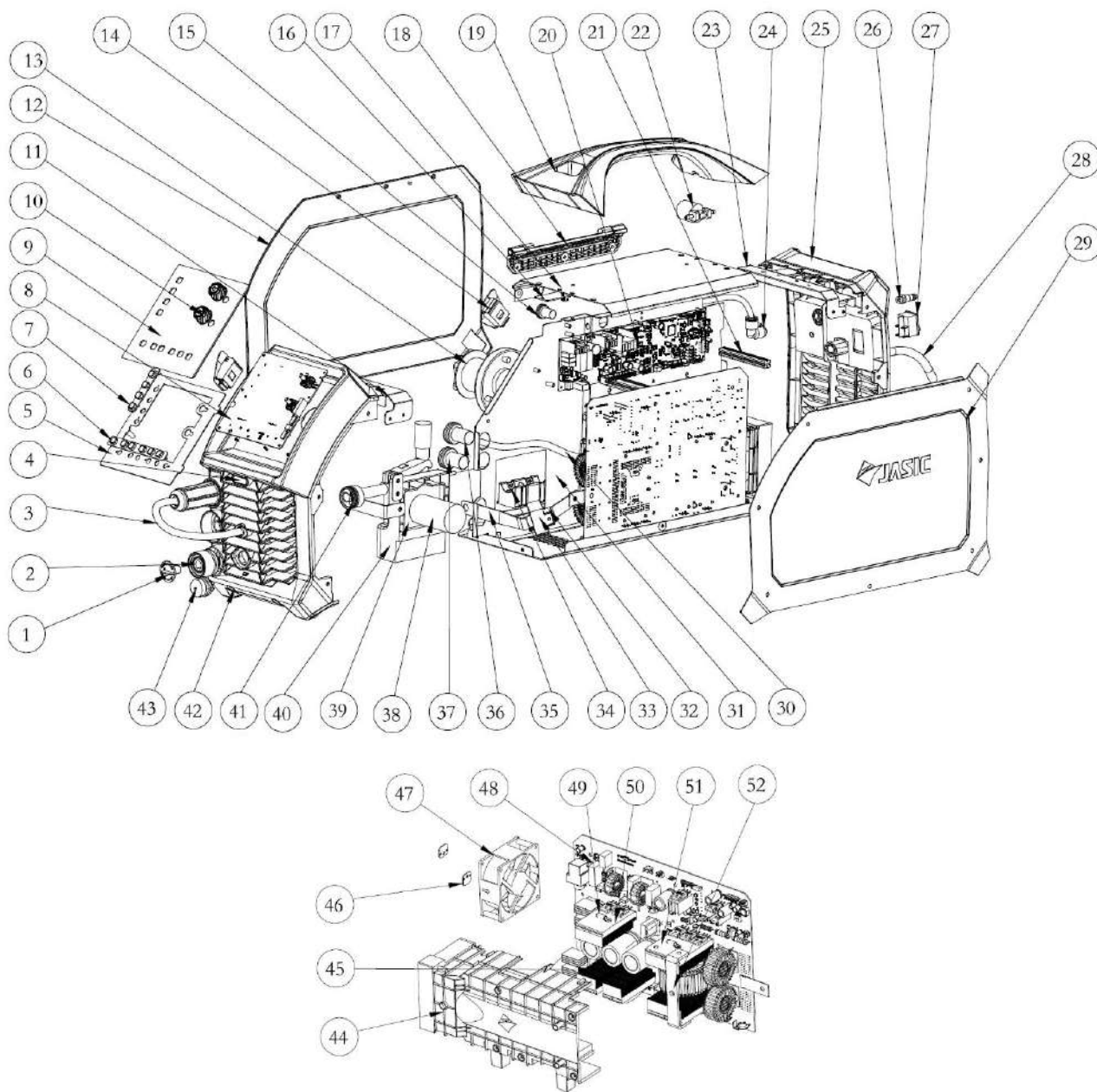

**List of spare parts
(Plus)**

SN	Material code	Name	Quantity	SN	Material code	Name	Quantity
2	10021855	Quick socket	2	39	51000695	Wire feeder	1
3	51000684	Quick coupling	1	41	51000824	Central socket	1
8	51000875	Display panel	1	43	51000686	9-pin aviation socket and cable	1
10	10083484	Knob	2	47	51000780	Fan	1
16	51001033	Wire feeder light board	1	48	51001005	Main board	1
20	51001002	Main control board	1	49	51000704	IGBT thermal resistor	1
22	51000711	Gas valve	1	51	51000703	Secondary rectifier thermal resistor	1
27	51000471	Power switch	1				
33	51000691	Hall sensor	1				

(Standard)

SN	Material code	Name	Quantity	SN	Material code	Name	Quantity
2	10021855	Quick socket	2	39	51000695	Wire feeder	1
3	51000684	Quick coupling	1	41	51000824	Central socket	1
8	51000875	Display panel	1	43	10042529	Plastic cover	1
10	10083484	Knob	2	47	51000780	Fan@MIG200	1
16	51001033	Wire feeder light board	1	48	51001816	Fan@MIG160	1
20	51001863	Main control board	1	4948	51001005	Main board	1
22	51000711	Gas valve	1	49	51000704	Secondary rectifier thermal resistor	1
27	51000471	Power switch	1	51	51000703	IGBT thermal resistor	
33	51000691	Hall sensor	1				

List of common spare parts 2 - MIG160PFC/MIG200PFC

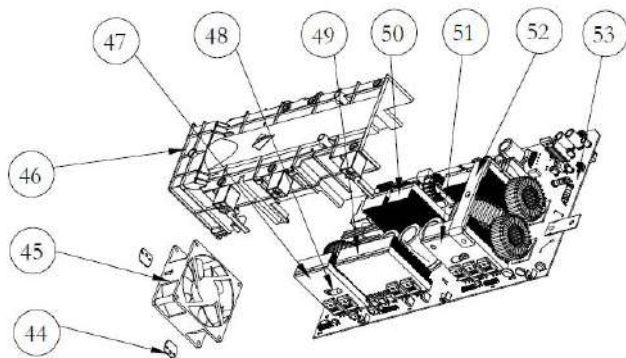
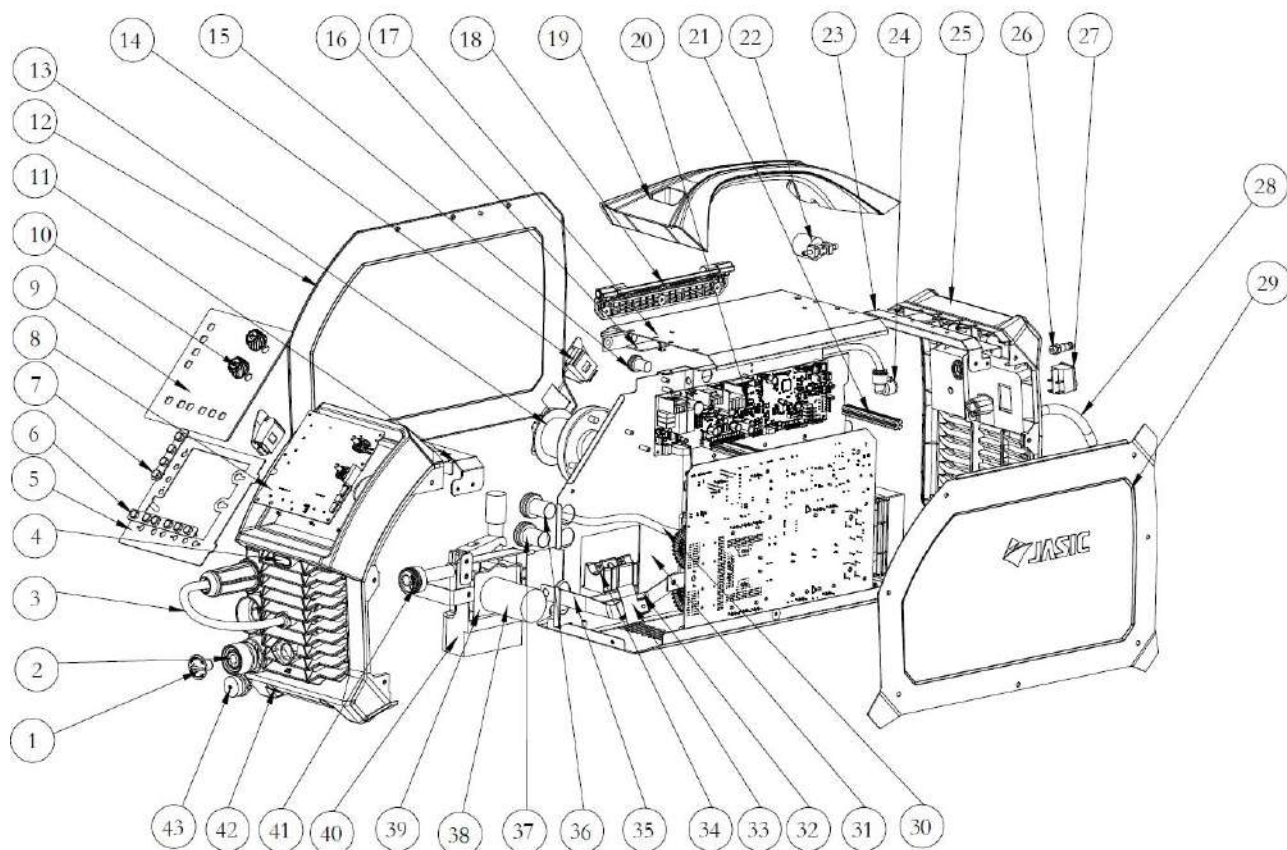

**List of spare parts
(Plus)**

SN	Material code	Name	Quantity	SN	Material code	Name	Quantity
2	10021855	Quick socket	2	39	51000824	Wire feeder	1
3	51000684	Quick coupling	1	41	51000944	Central socket	1
8	51000875	Display panel	1	43	51000686	9-pin aviation socket and cable	1
10	10083484	Knob	1	45	51000778	Fan	1
16	51001033	Wire feeder light board	1	53	51001006	Main board@MIG160PFC	1
20	51001014	Main control board	1		51001007	Main board@MIG200PFC	1
22	51000711	Gas valve	1	48	51000706	Thermal resistor	1
27	51000471	Power switch	1				
33	51000691	Hall sensor	1				

(Standard)

SN	Material code	Name	Quantity	SN	Material code	Name	Quantity
2	10021855	Quick socket	2	39	51000824	Wire feeder	1
3	51000684	Quick coupling	1	41	51000944	Central socket	1
8	51000875	Display panel	1	43	10042529	Plastic cover	1
10	10083484	Knob	1	45	51001816	Fan@MIG160	1
16	51001033	Wire feeder light board	1	48	51000778	Fan@MIG200	1
20	51001854	Main control board	1	53	51001006	Main board@MIG160PFC	1
22	51000711	Gas valve	1		51001007	Main board@MIG200PFC	1
27	51000471	Power switch	1	48	51000706	Thermal resistor	1
33	51000691	Hall sensor	1				

List of common spare parts 3 - MIG250

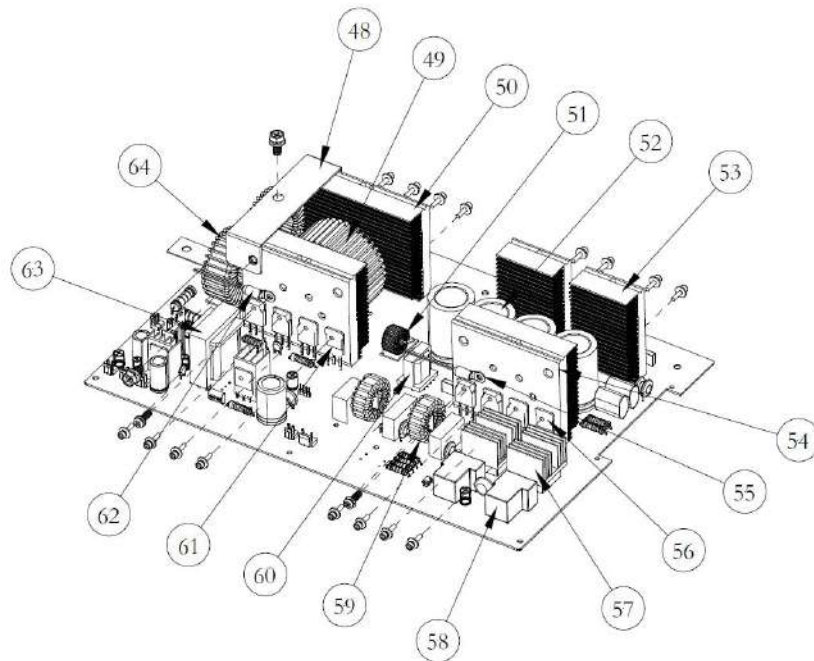
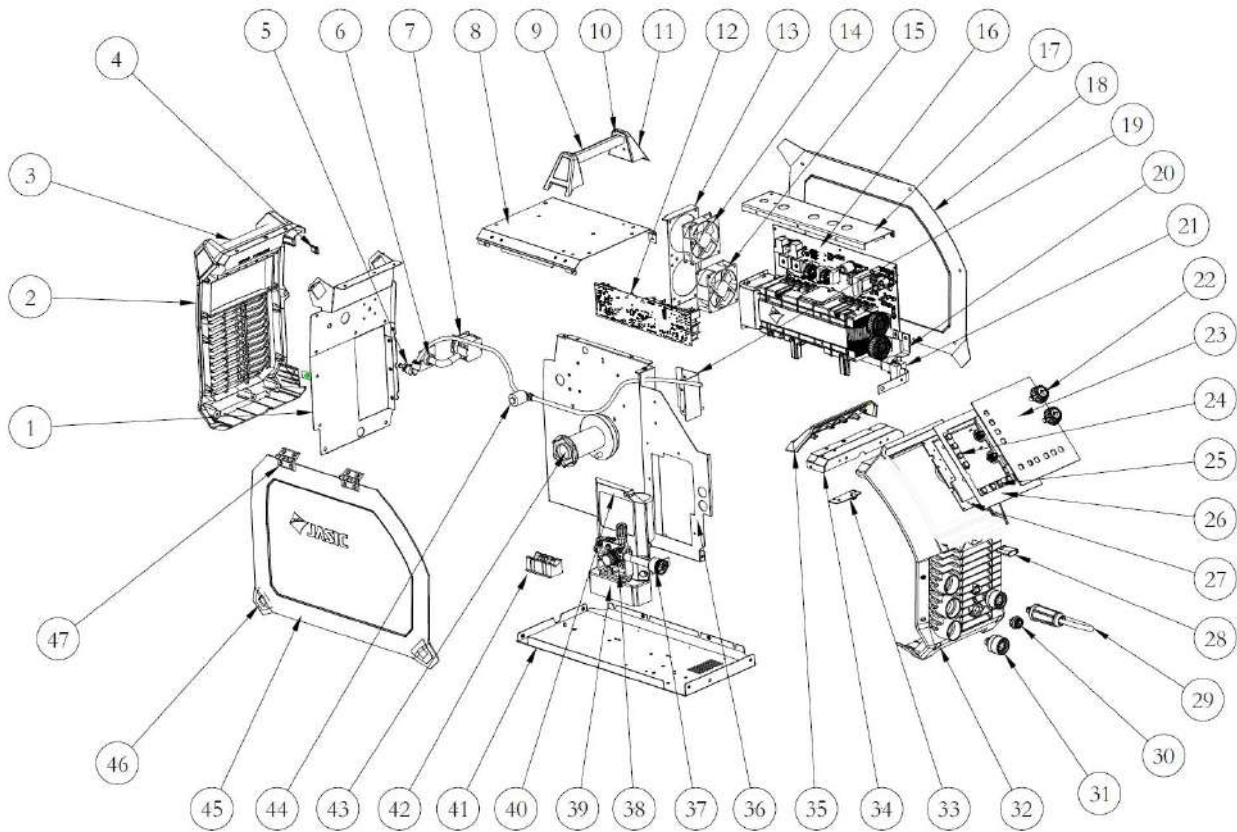

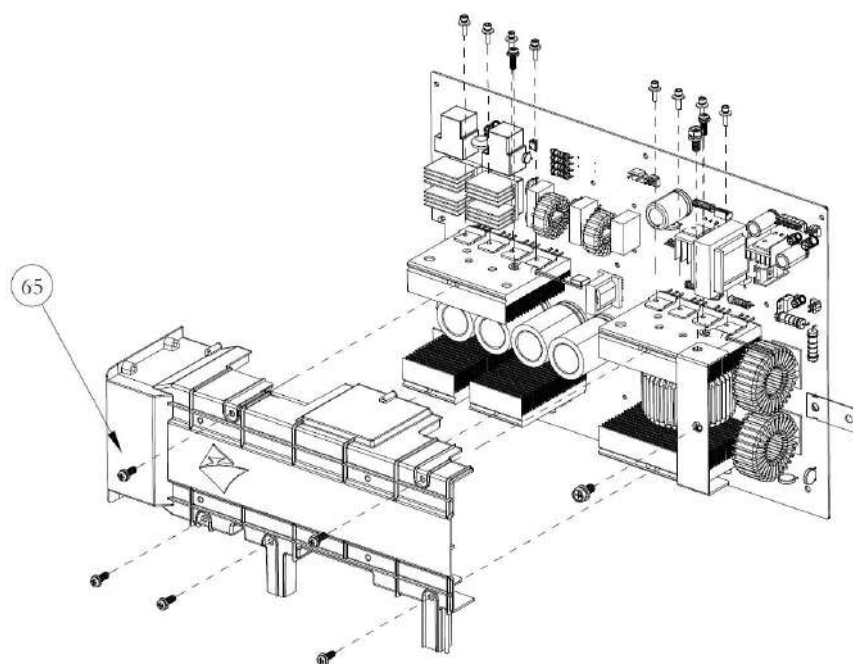

List of spare parts

(Plus)

SN	Material code	Name	Quantity	SN	Material code	Name	Quantity
7	10084286	Knob switch	1	31	10021855	Quick socket	2
12	51001027	Main control board	1	33	51001033	Wire feeder light board	1
14	51001816	Fan (small)	1	37	51000966	Central socket	1
15	51000778	Fan (large)	1	38	51000967	Wire feeder	1
16	51001003	Main board	1	44	51000962	Gas valve	1
21	10084574	Hall sensor	1	55	51000703	IGBT thermal resistor	1
22	10084265	Knob	2	62	51000704	Secondary rectifier thermal resistor	1
27	51001029	Display panel	1				
29	51000968	Quick coupling	1				
30	10084575	9-pin aviation socket and cable	1				

(Standard)

SN	Material code	Name	Quantity	SN	Material code	Name	Quantity
7	10084286	Knob switch	1	31	10021855	Quick socket	2
12	51002079	Main control board	1	33	51001033	Wire feeder light board	1
14	51001816	Fan (small)	1	37	51000966	Central socket	1
15	51000778	Fan (large)	1	38	51000967	Wire feeder	1
16	51001003	Main board	1		51000962	Gas valve	1
21	10084574	Hall sensor	1	55	51000703	IGBT thermal resistor	1
22	10084265	Knob	2	62	51000704	Secondary rectifier thermal resistor	1
27	51001029	Display panel	1				
29	51000968	Quick coupling	1				
30	10042529	Plastic cover	1				

List of common spare parts 4 - MIG250PFC

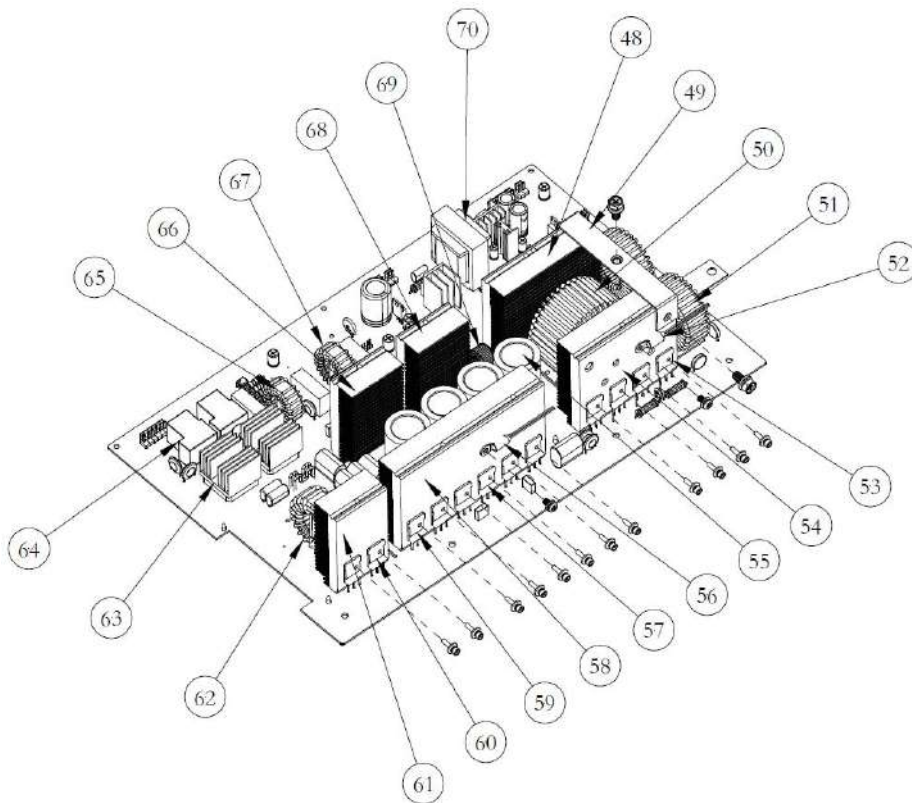
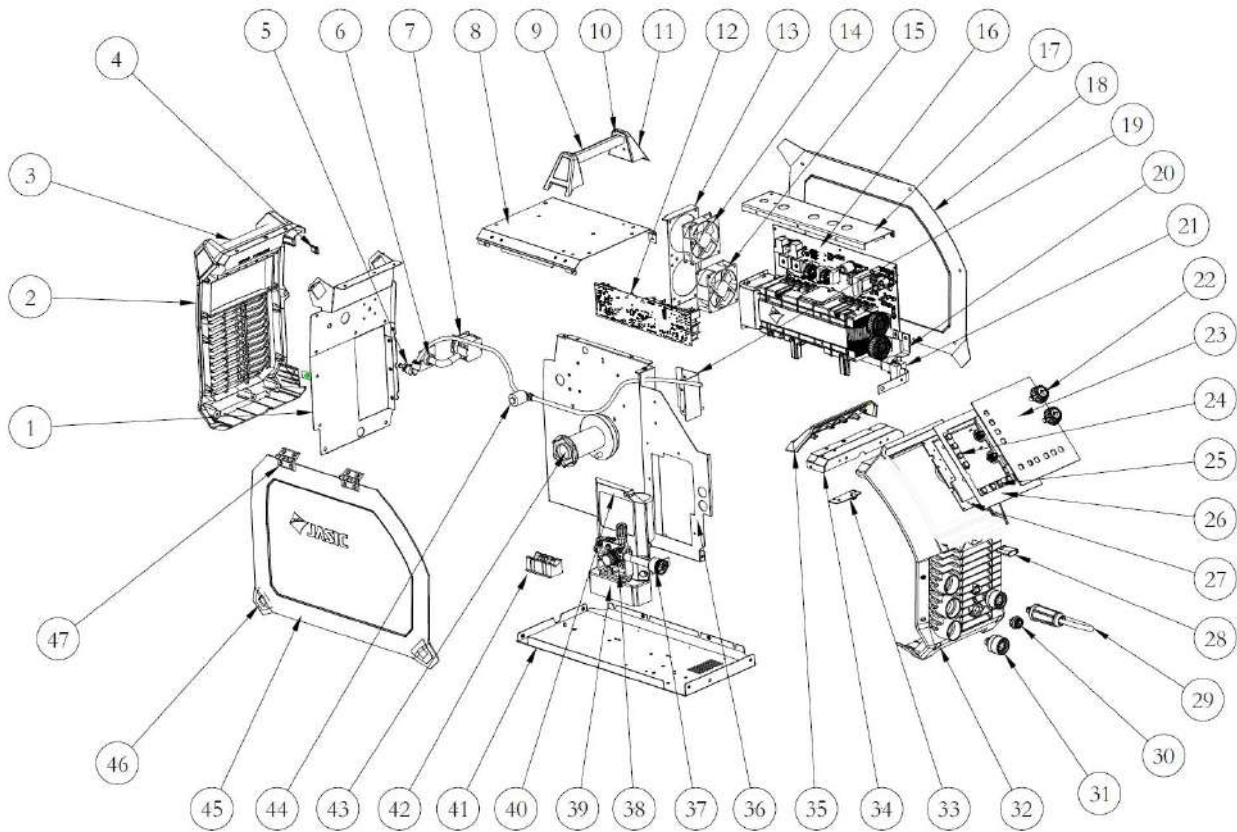

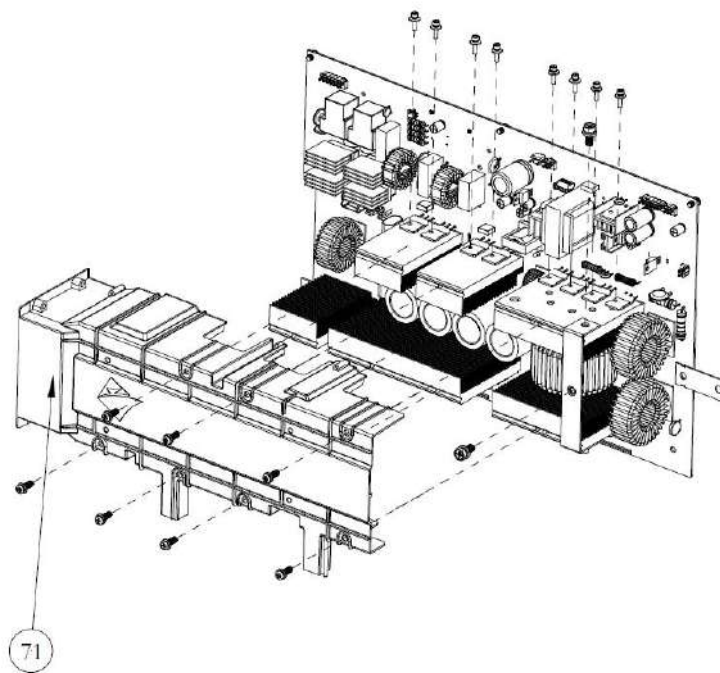

**List of spare parts
(Plus)**

SN	Material code	Name	Quantity	SN	Material code	Name	Quantity
7	10084286	Knob switch	1	31	10021855	Quick socket	2
12	51001022	Main control board	1	33	51001033	Wire feeder light board	1
14	51001816	Fan (small)	1	37	51000975	Central socket	1
15	51000778	Fan (large)	1	38	51000974	Wire feeder	1
16	51001013	Main board	1	44	51000962	Gas valve	1
21	10084574	Hall sensor	1	54	51000708	Secondary rectifier thermal resistor	1
22	10084265	Knob	2	56	51000707	IGBT thermal resistor	1
27	51001029	Display panel	1				
29	51000968	Quick coupling	1				
30	10084575	9-pin aviation socket and cable	1				

(Standard)

SN	Material code	Name	Quantity	SN	Material code	Name	Quantity
7	10084286	Knob switch	1	31	10021855	Quick socket	2
12	51001812	Main control board	1	33	51001033	Wire feeder light board	1
14	51001816	Fan (small)	1	37	51000966	Central socket	1
15	51000778	Fan (large)	1	38	51000967	Wire feeder	1
16	51001013	Main board	1	44	51000962	Gas valve	1
21	10084574	Hall sensor	1	54	51000708	Secondary rectifier thermal resistor	1
22	10084265	Knob	2	56	51000707	IGBT thermal resistor	1
27	51001029	Display panel	1				
29	51000968	Quick coupling	1				
30	10042529	Plastic cover	1				

Appendix 3 Packaging and parts

SN	Name	Unit	Quantity
1	Product certificate	Copy	1
2	Warranty card	Copy	1
3	Desiccant	Pcs	2
4	Accessories	Pcs	1
5	Welder	Pcs	1

General packaging

Parts of MIG160/MIG160PFC/MIG200/MIG200PFC (plus)

SN	Classification	Name	Material code	Unit	Quantity
1	Earth clamp	300A-16mm2-KDP70A(3M)	10021496	Pcs	1
2	MIG welding torch	MB-15(3M) BINZEL	10019692	Pcs	1
3	Hose clamp	9-16mm	10057339	Pcs	2
4	Waterproof socket	Φ6.5x3 (without fastening nut and washer)	10038768	Pcs	1

Parts of MIG160/MIG160PFC/MIG200/MIG200PFC (standard)

SN	Classification	Name	Material code	Unit	Quantity
1	Earth clamp	300A-16mm2-KDP70A(3M)	10085594	Pcs	1
2	MIG welding torch	MB-15(3M) BINZEL	10019692	Pcs	1
3	Hose clamp	9-16mm lead-free	10057339	Pcs	2

Parts of MIG250/MIG250PFC (plus)

SN	Classification	Name	Material code	Unit	Quantity
1	Earth clamp	300A-16mm2-DKJ35-50(3M)	10043956	Set	1
2	MIG welding torch	MB-24(3M)	51000536	Set	1
3	Hose clamp	American-style hose clamp: 9-16mm lead-free	10057339	Pcs	2
4	Socket	Waterproof socket: Φ6.5x3 (without fastening nut and washer)	51000445	Pcs	1

Parts of MIG250/MIG250PFC (standard)

SN	Classification	Name	Material code	Unit	Quantity
1	Earth clamp	300A-16mm2-DKJ35-50(2.5M)	10085594	Set	1
2	MIG welding torch	MB-24(3M)	51000536	Set	1
3	Hose clamp	American-style hose clamp: 9-16mm	10057339	Pcs	2

 **JASIC®** | Passionate About Your Welding

SHENZHEN JASIC TECHNOLOGY CO., LTD.

Address: No. 3, Qinglan 1st Road, Pingshan District, Shenzhen, Guangdong, China

Postcode: 518118

Tel: +86 (0755) 8670 6250

Fax: +86 (0755) 2736 4108

Website: www.jasitech.com

E-mail: sales@jasitech.com

 @JASICTechWelding

 JASIC Technology Co., Ltd.

 @jasitech_official